

In-Transit Cleaning of Hulls

ITCH - User Manual

For operations with portable air winch

Rev. 1.0



Shipshave

Table of Contents

[01 – Introduction of ITCH v.1](#)

[02 – Before First Use](#)

[03 - Unboxing & Assembly](#)

[04 – Operating ITCH](#)

[05 – ITCH Application](#)

[06 – Robot Charging & Status Lights](#)

[07 – Camera Operation](#)

[08 – Safety Precautions](#)

[Appendix](#)

[A - Replacing the Camera](#)

[B – Advanced Settings](#)

[C - Custom Depth Settings](#)

[D – High speed ships](#)

[E – Brush Selection](#)

[F - Maintenance](#)

Click on the [section name](#) to jump to that section.

01 – Introduction of ITCH



View the demonstration video by
clicking below icon or
watch «Shipshave-ITCH.mp4» video
in the included memory stick

As an alternative you may access
the film via the web from:

www.shipshave.no

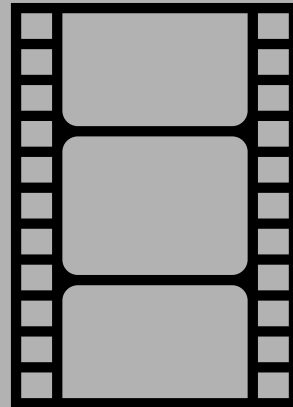

ITCH v.1

Start with a clean hull. Keep it clean with In-Transit Cleaning of Hulls.

02 – Before First Use





Review the supplied documentation to understand how to best utilize the ITCH to maintain the vertical sides free from fouling. Contact Shipshave (support@shipshave.no) prior to commencing operations if the User Manual is unclear.

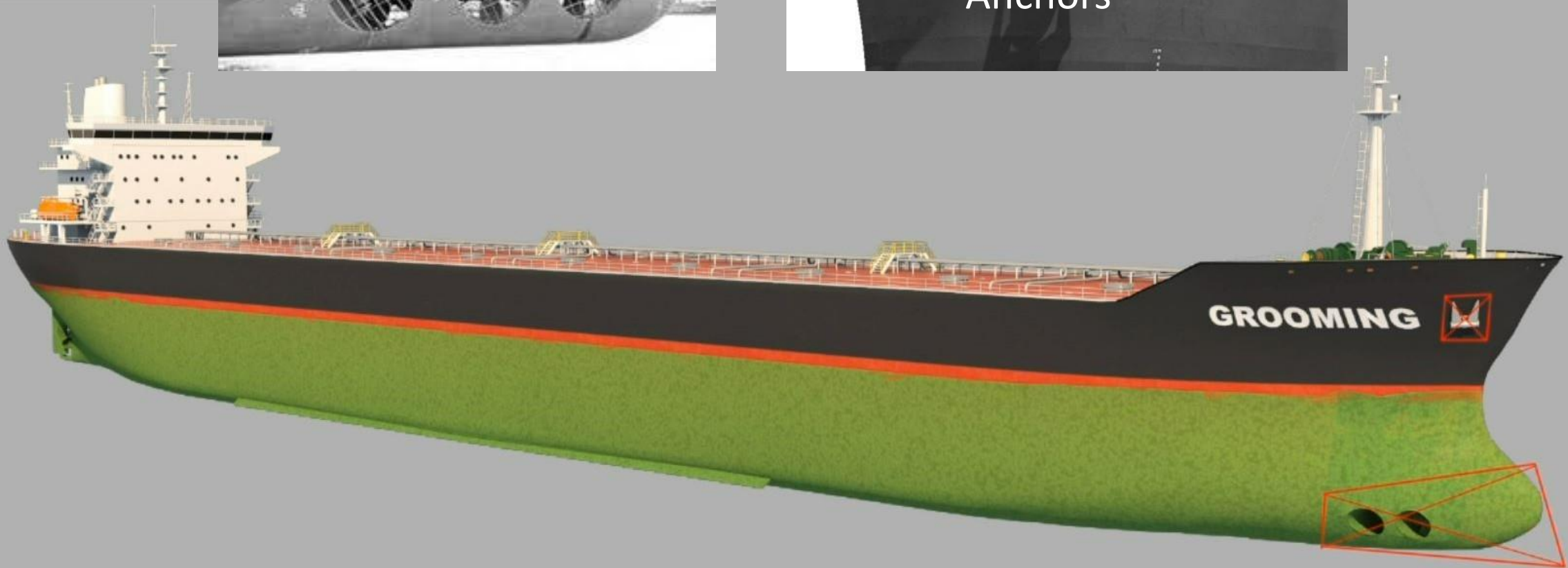

Assess the location of any obstructions such as thrusters and sea chests on the hull that can limit the travel of the robot. Identify the optimal locations for deployment and retrieval of the robot.

03 - Unboxing & Assembly



ITCH Kit Contents

- 1 Portable electric winch
- 1 ITCH profile
- 2 Sets of brushes
- 1 Tail with camera
- 1 Nose
- 1 Tow-bar with arm
- 1 Rudder
- 1 Camera securing line



Tools & Accessories

- Robot charger
- Camera charging cable & accessories
- SD card adapter
- USB memory stick with software & user manuals
- (4) M8 x 70mm bolts
- (2) M6 x 15mm bolts
- (2) Tow-bar nuts
- 6mm hex key (For M8 bolts)
- 5mm hex key (For M6 bolts)
- 17mm wrench (For tow-bar nut)

Robot Assembly – Step 1

Check that you have all the required parts for a robot assembly.

Robot profile

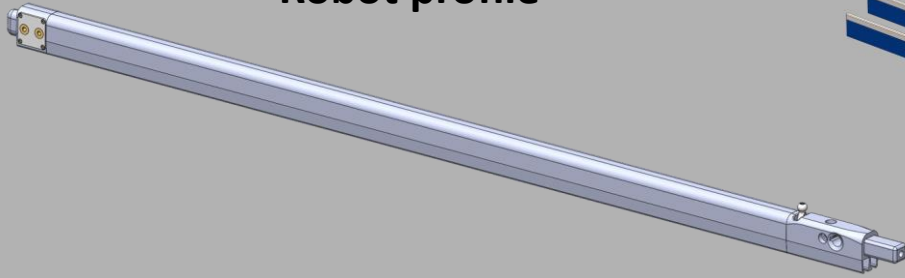

Brushes

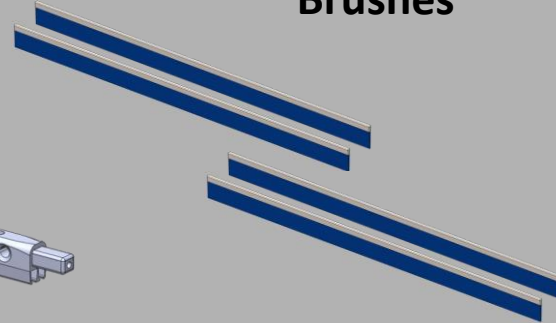

Tow bar with nut & Arm

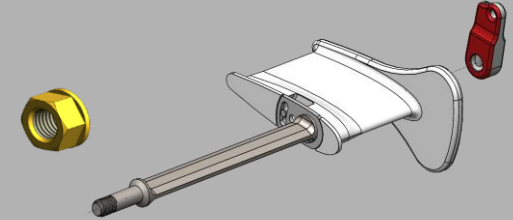

Rudder with M6 bolt

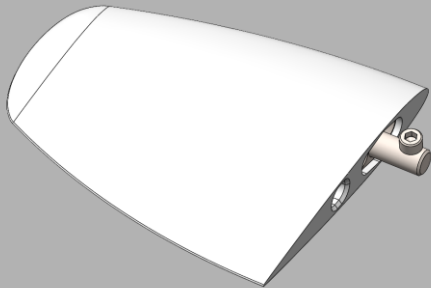

Nose with M8 bolt

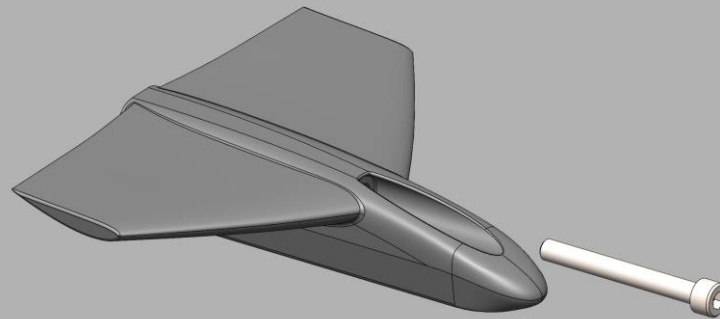

Tail with camera, M8 bolt & security line

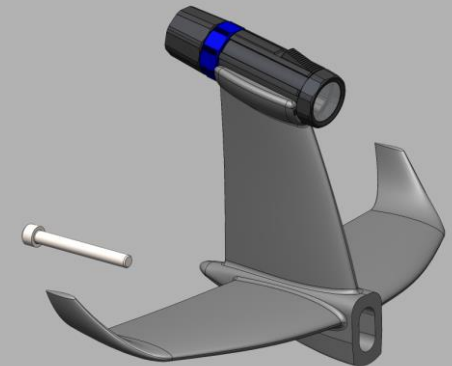

Robot Assembly – Step 2

Slide the brushes into ITCH robot profile

- Slide the brushes in by hand power
- Do not use excessive power to fit the brushes
- Check the brushes remain straight and add lubrication if resisting

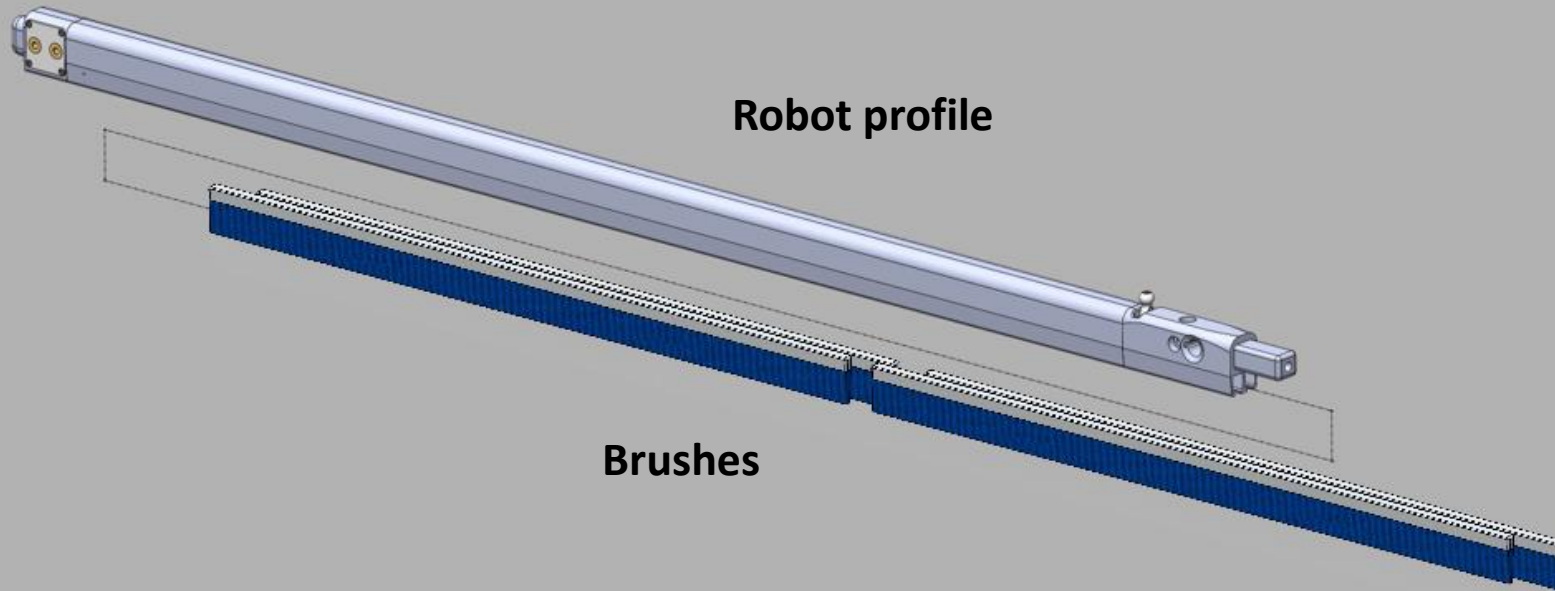

Robot Assembly – Step 3

Attach external parts

- Orient the tow-bar according to side of ship to be cleaned

- Secure camera with the security line

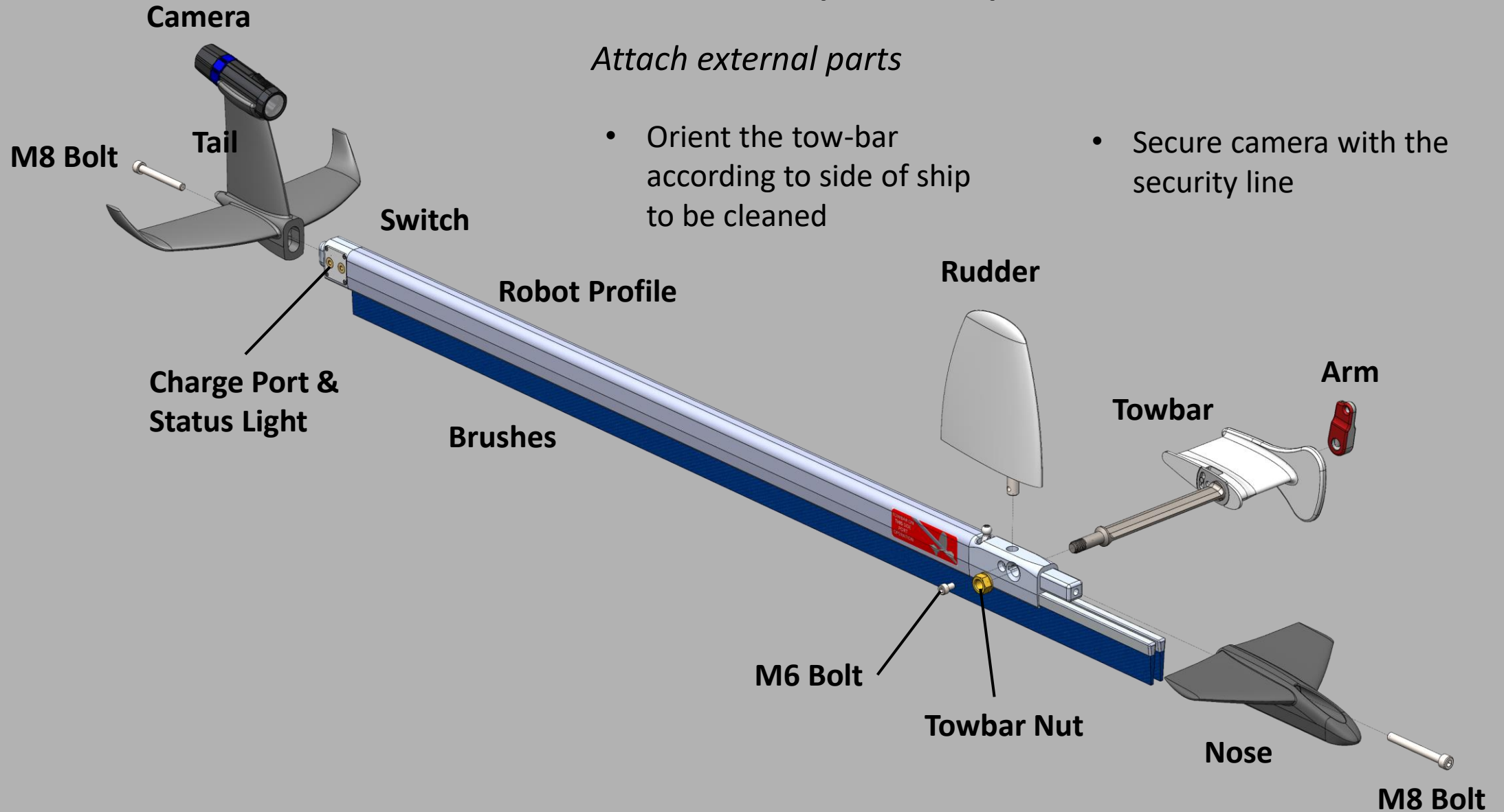

04 - Operating ITCH



Camera – Quick Start Guide

Getting started

Here we present some of the things you need to know, to safely get started with your brand new Paralenz camera.

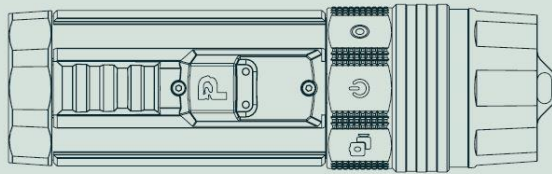

Pull back and hold

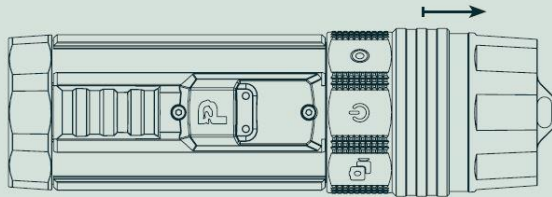

The end cap

The first thing to know about the Vaquita camera is; how to take off the protective end cap for charging or handling the SD-card.

As pictured on the illustrations above, you need to pull back the “collar” on the end cap, to get it off. While holding this back, you will be able to pull off the end cap.

The same mechanism is used when you put the end-cap back on. Pull back the “collar”, push it back on.

SD-Card

Remove the end cap and insert a micro SD-card. **It must be a Sandisk card with class U3 or V30.**

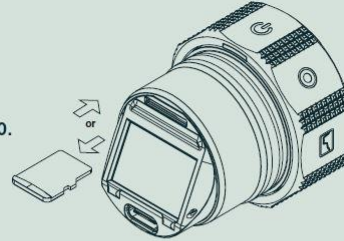

A capacity of **32 GB** or more is recommended. A full memory card is as useful as no memory card! Make sure to empty the SD-card after each export.

Turn on camera

Select the power icon  on the selector ring and hold the activation switch for 4 sec. To turn off again hold for 4 sec. while on Power mode.

Hold 4 sec.

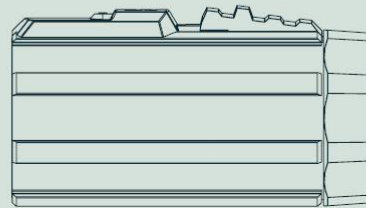

Select mode

Turn the selector ring so the icon of your desired mode is facing upwards. You can choose between the following; Power, Snap, Video, Custom I, Custom II, Settings, Dive Logs, and Location.

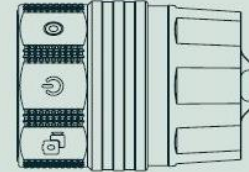

Video

To record a video select the video mode on the selector ring, and the camera will confirm with vibration. To start recording hold the activation switch for 1 sec. To stop recording hold for 1 sec.

Battery & charging

Use an USB-C to USB-A charger that can deliver 2.1A for fast charging. Make sure the battery is charged before you enter the water. Maintain the camera battery by charging it every second month, if not in use.

Prepare the robot

- Charge the robot
- Charge the camera
- Clear memory of SD-card and place it in the camera
- Clear the memory in the robot

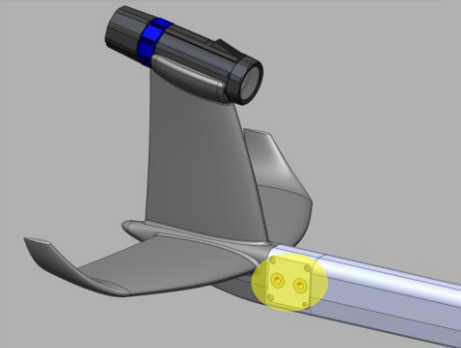

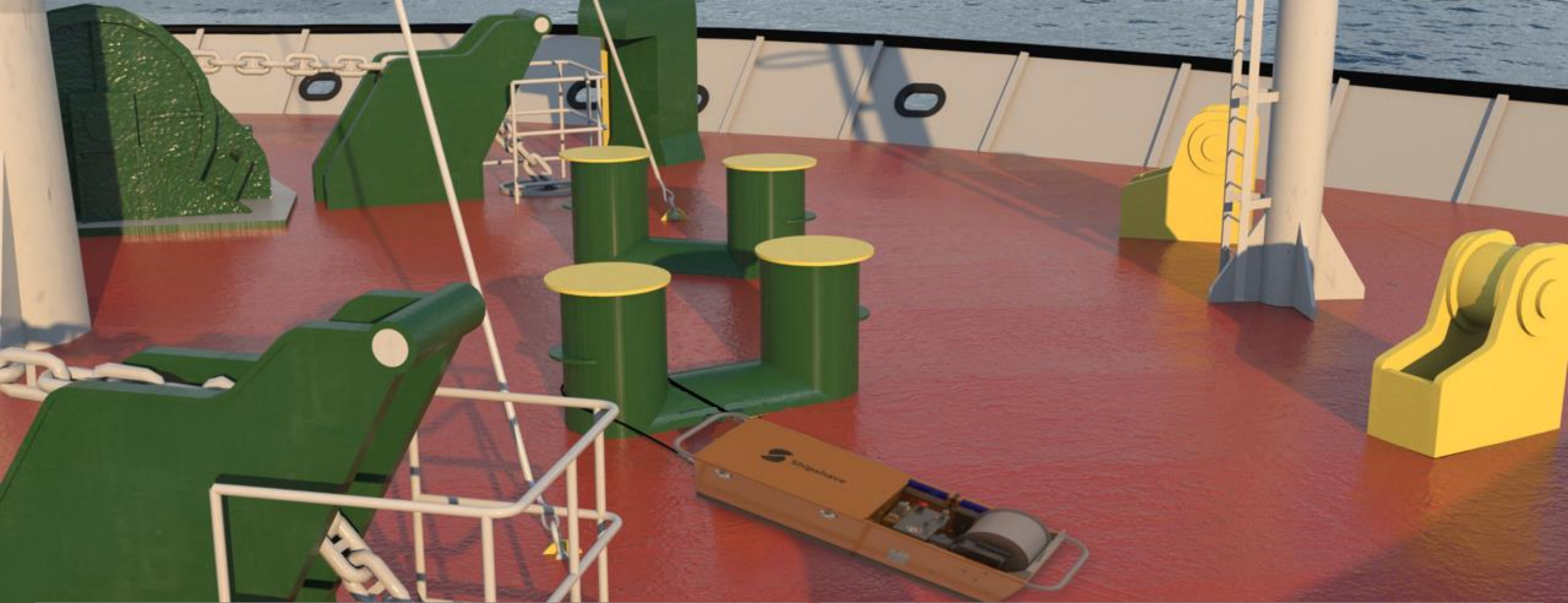

Evaluate Conditions:

- Maintain 10 -15 knots through the water during the operation. Refer to **Appendix D** for ship speed above 15 knots.
- Prefer to operate in calm seas. Avoid operations when the wave height is above 3m.
- Operation during daylight enhance crew safety and video recording.
- Assess and avoid obstructions on the hull.
- Avoid areas with fishing gear, floating debris or marine vegetation.

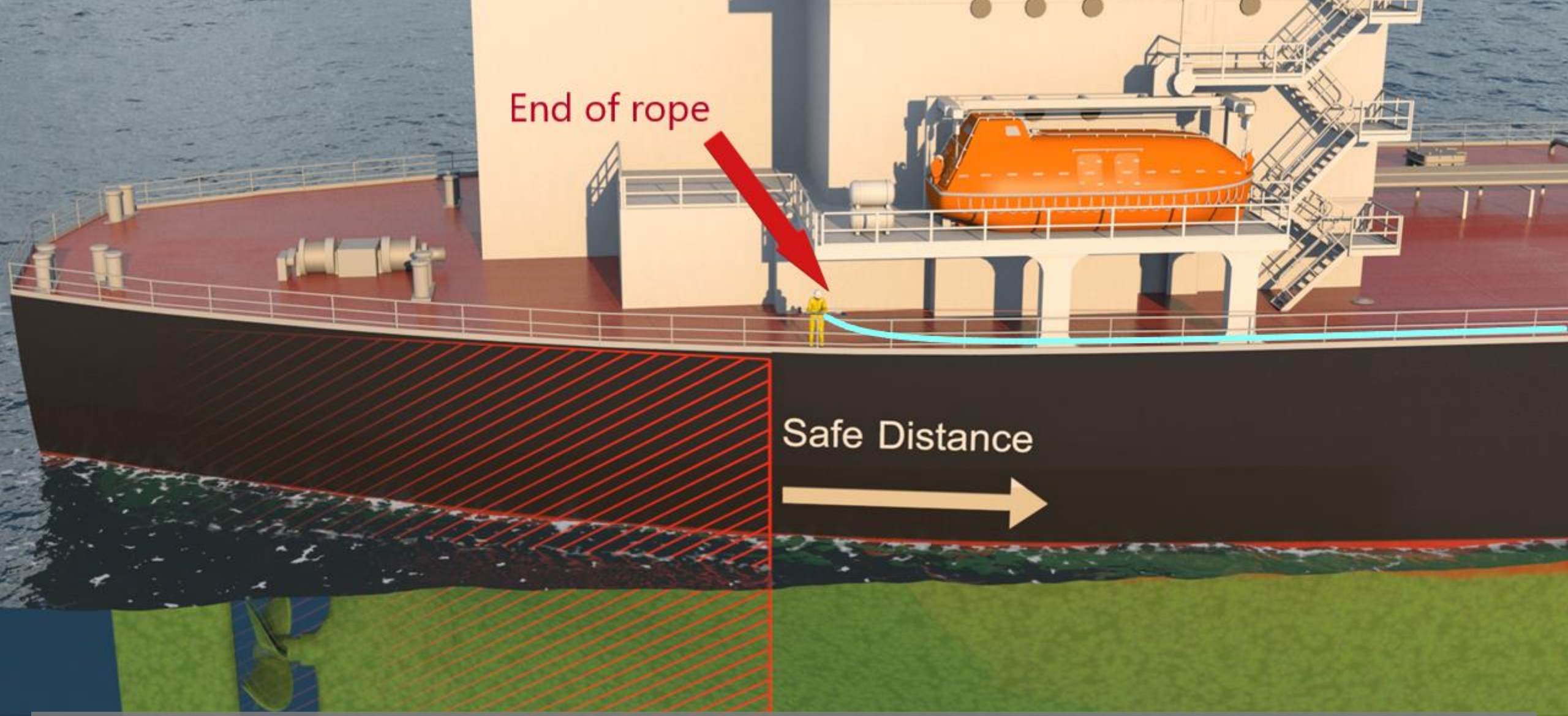

Rope setup:

Prior to first use of the ITCH, unspool the rope and pull towards the aft to verify that the rope cannot reach the propeller. Cut or secure the rope length on the winch so that the ITCH robot cannot reach the propeller.

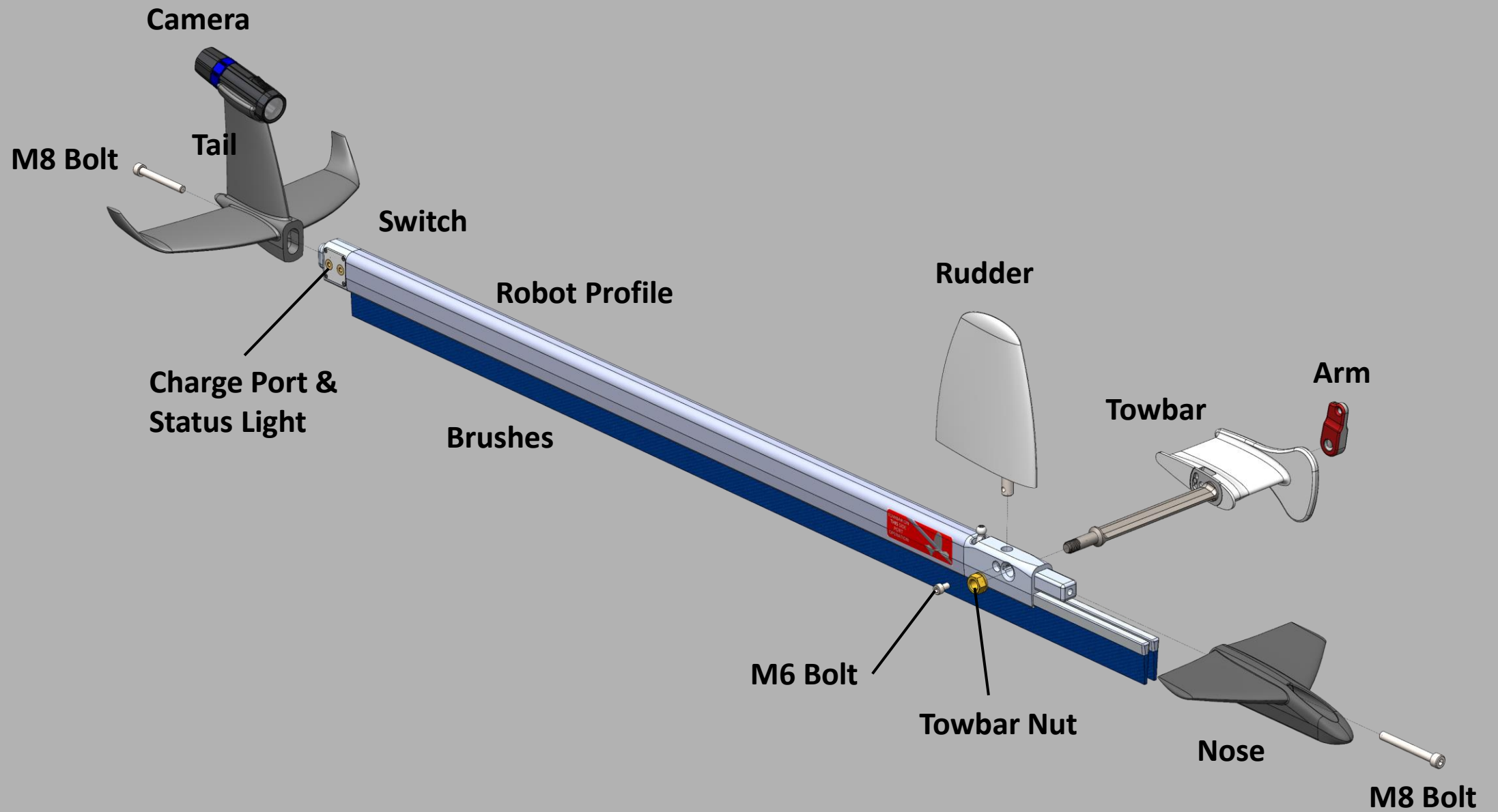

Assemble the ITCH robot using the tools and 3 bolts + 1 nut provided in the transport & storage case. Firmly hand tighten bolts and nut. Tie the rope to the arm with a bow knot.

Towbar Position

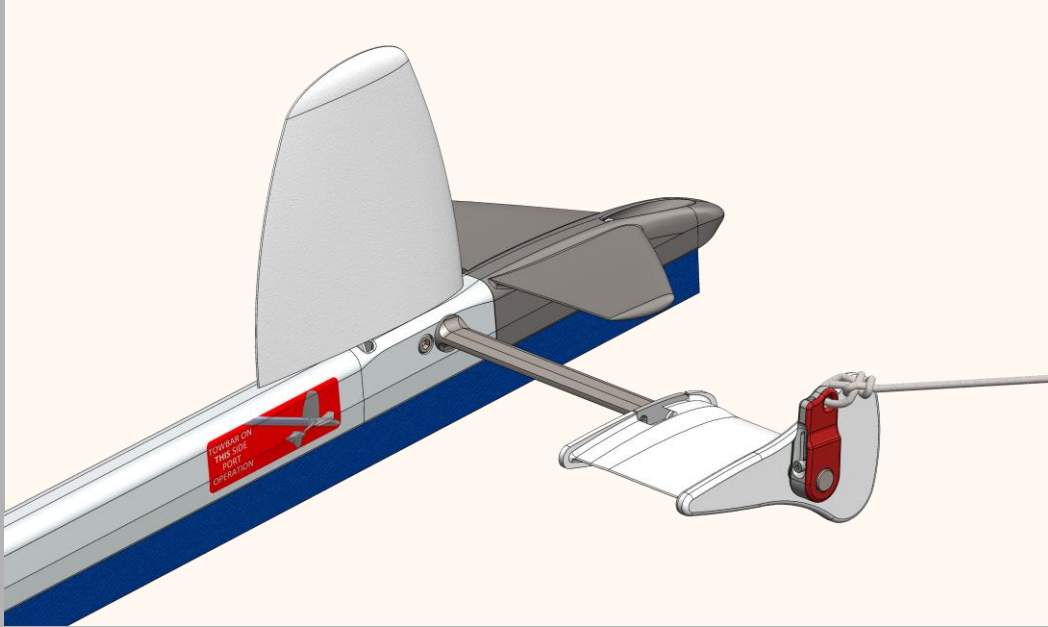

Port operation

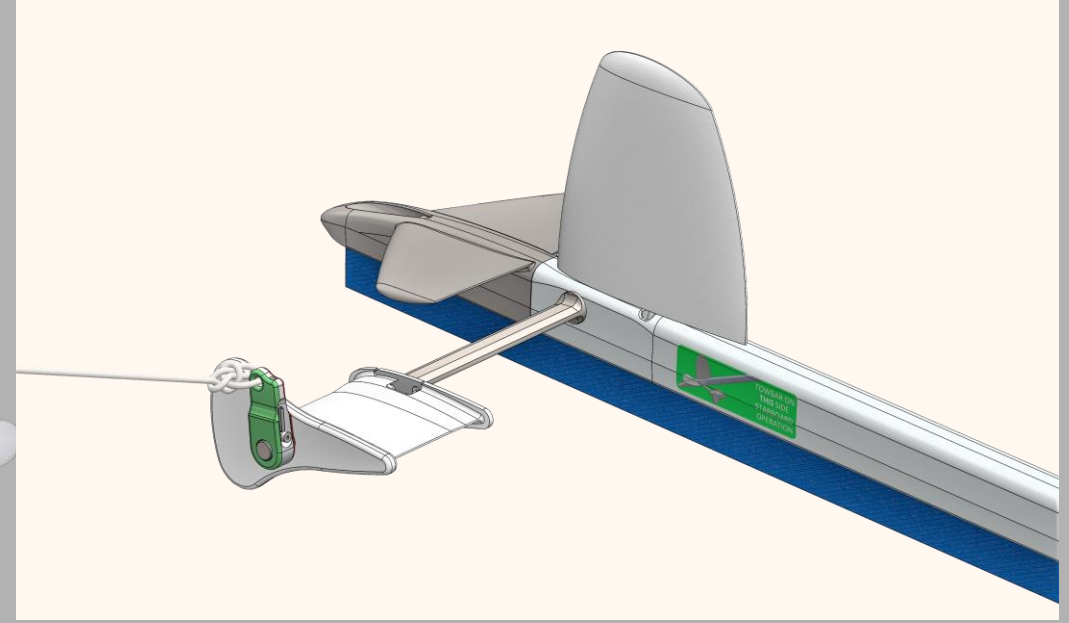

Starboard operation

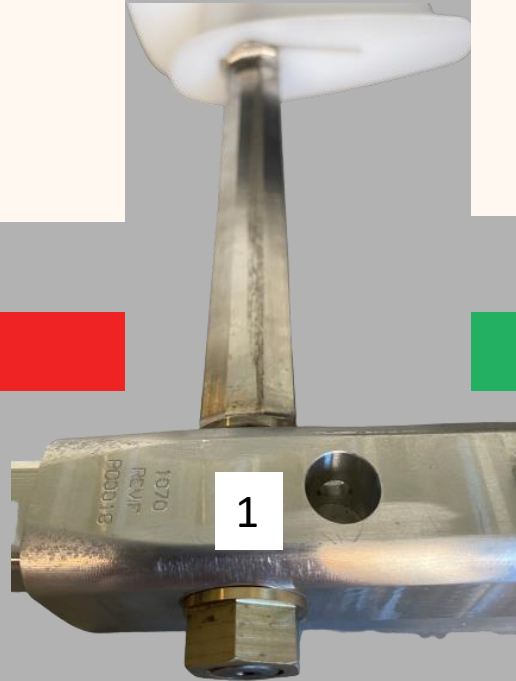

The same towbar is used for both sides of the hull. Switch sides of the towbar to alternate between port and starboard side operation by unscrewing and fastening the nut (1). The robot is clearly marked for Port and Starboard side operations. Swap sides of the arm.

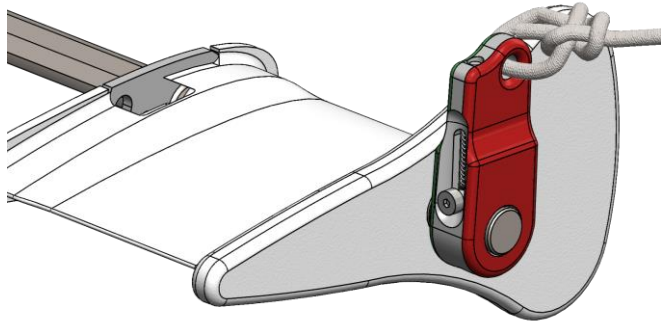

Arm position for port side operation

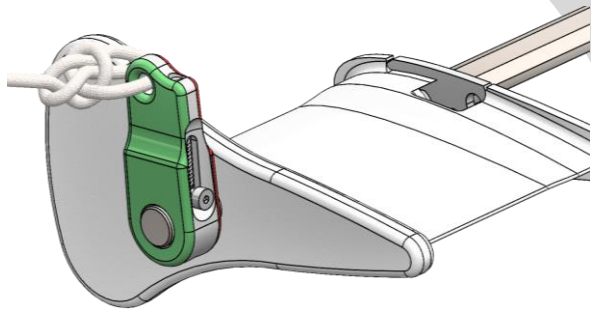

Arm position for starboard side operation



Arm Position

- The arm should be fitted to the towbar end as shown in the pictures.
- Avoid large knots to minimize the water resistance. The towing line is Dyneema rope with low friction.
- Use a bowline knot.

Fitting Arm to the Towbar

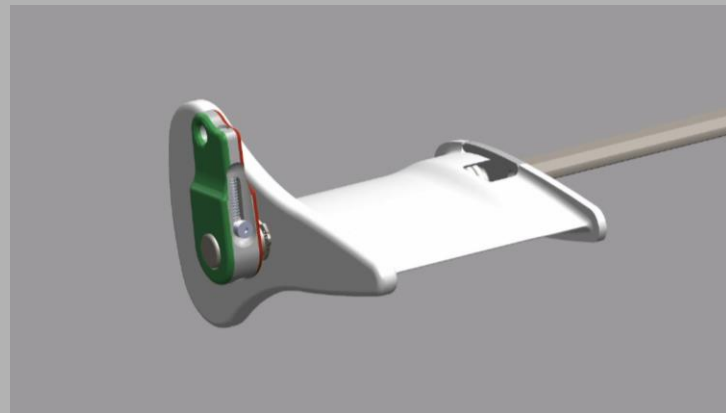
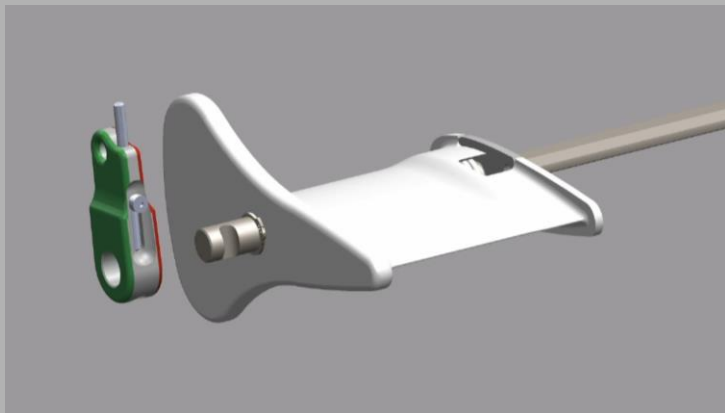
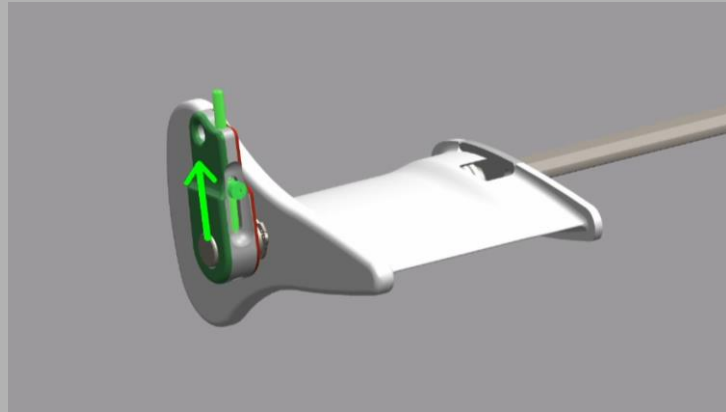
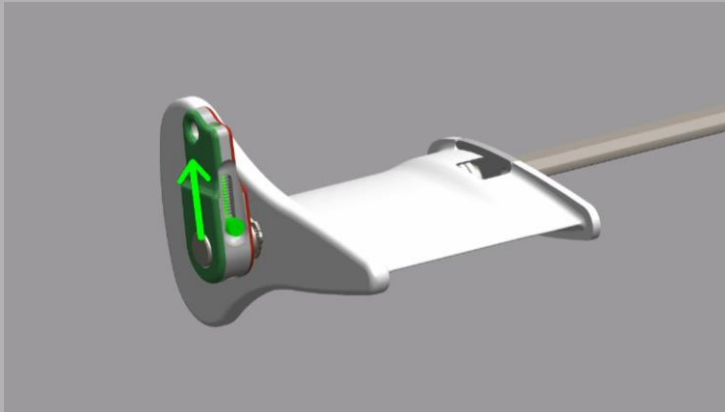

- Push the spring-loaded pin
- Insert the Arm to the towbar in the correct orientation
- Release the spring on the pin when Arm is fitted
- Make sure the Arm is fixed to the Tow bar

Caution: Do not fit the Arm upside down as shown in below image

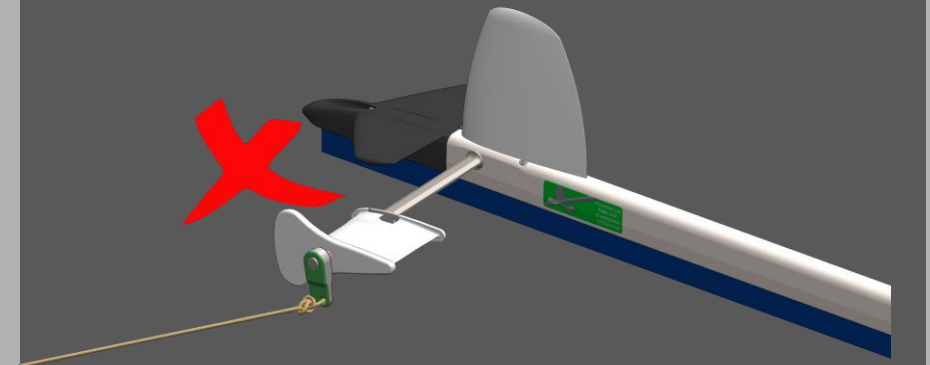

Setting up the winch

Assess which chock to use on the forecastle deck. For optimal coverage, deploy ITCH through the center line Panama chock. Prepare a clear route for the rope to travel without obstructions or pinch points. Limit the number of directional changes to minimize the friction. Connect the winch to the source of power.



Position of the winch

The portable winch must be safely secured to a strong point, such as a bollard. Rig and position the winch so that the rope leaves the drum towards the center line chock on the vessel. Keep the winch at least 5m away from the chock for efficient spooling.

Procedure to deploy ITCH through center line Panama chock

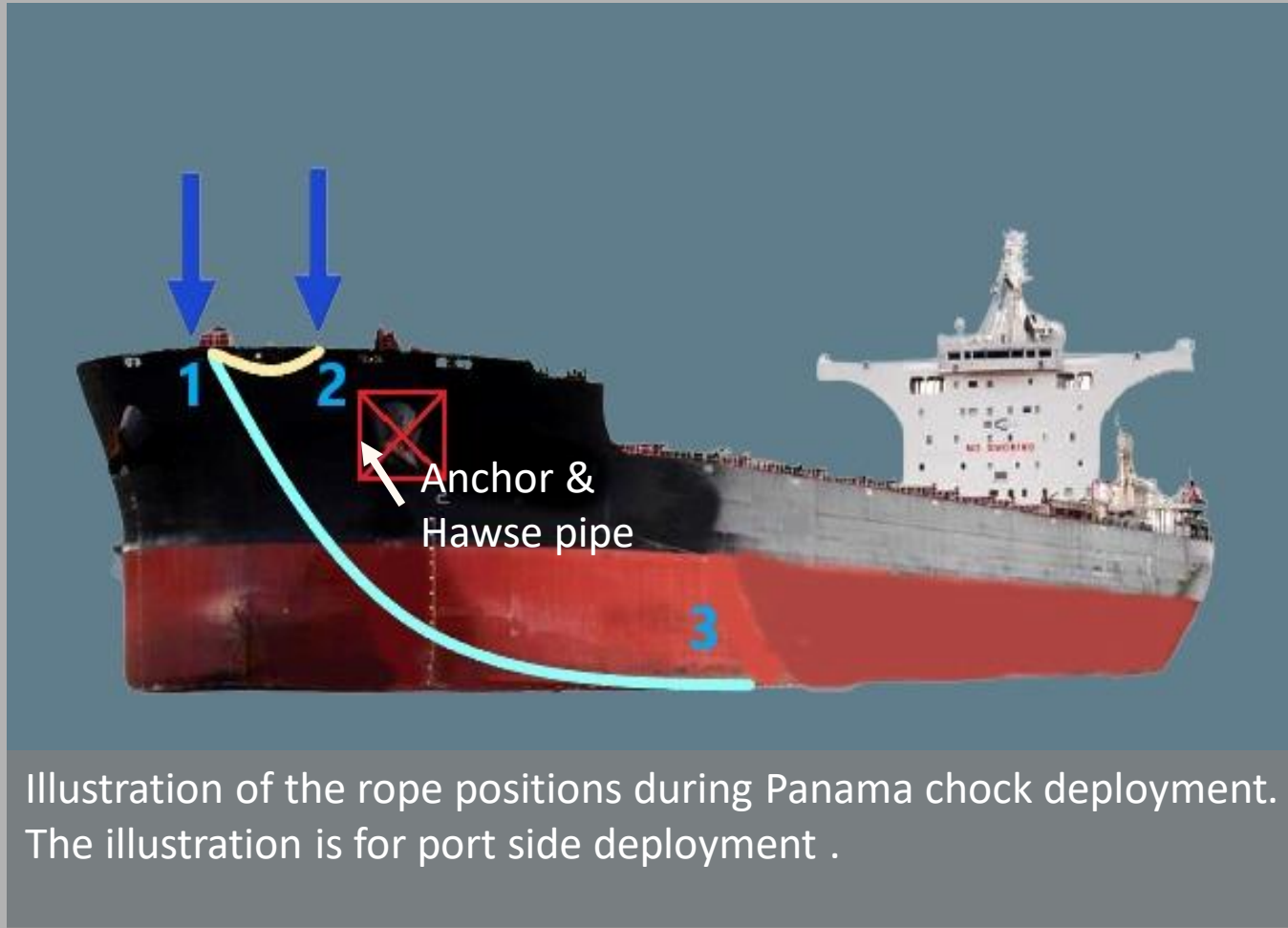

1. Align the winch with the center line Panama chock, pull the end of the rope through the chock and back on to the deck.
2. Connect the rope to the ITCH robot at 'position 2'.
3. Release the ITCH and spool out the rope at 'position 2' till the ITCH robot reaches the water so that the rope follows the 'position 3' path.
4. Reduce and adjust the winch speed when the ITCH robot dives under the water.

Procedure to deploy ITCH through center line Panama chock

- During the deployment through the Panama chock, the rope will experience a higher friction on the rope.
- The friction on the rope can be reduced using a sheave.
- A rope can be tied to a support structure and other end to the sheave with a carabiner.
- The end of the rope from the winch needed to be passed through the sheave before attaching the ITCH to the rope.



Rope from the winch



Sheave with Carabiner

Robot On / Off Switch

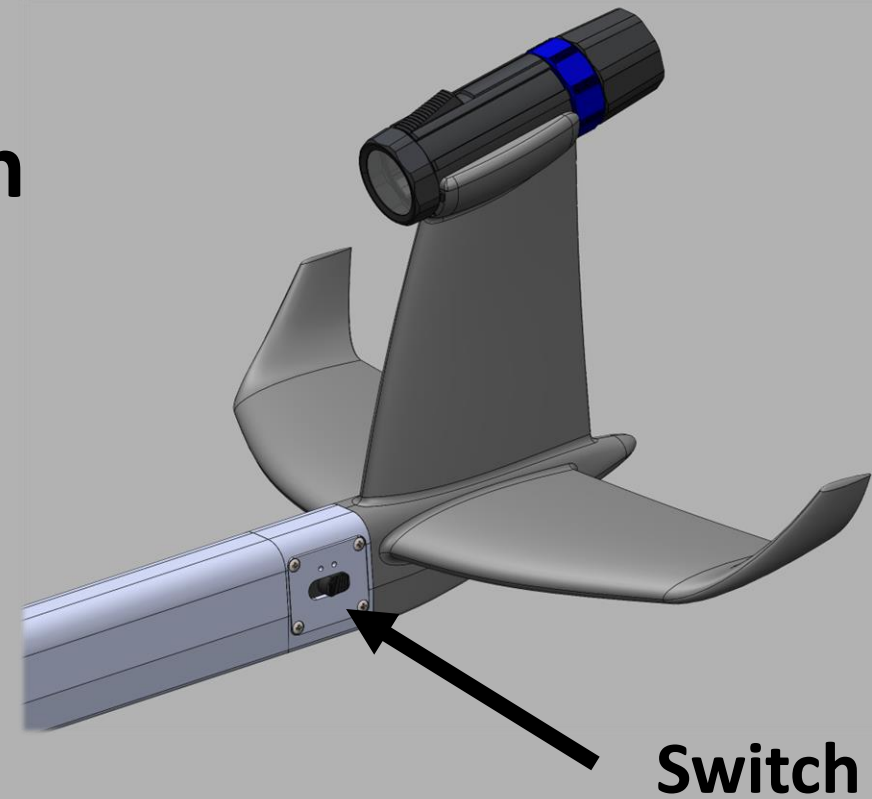
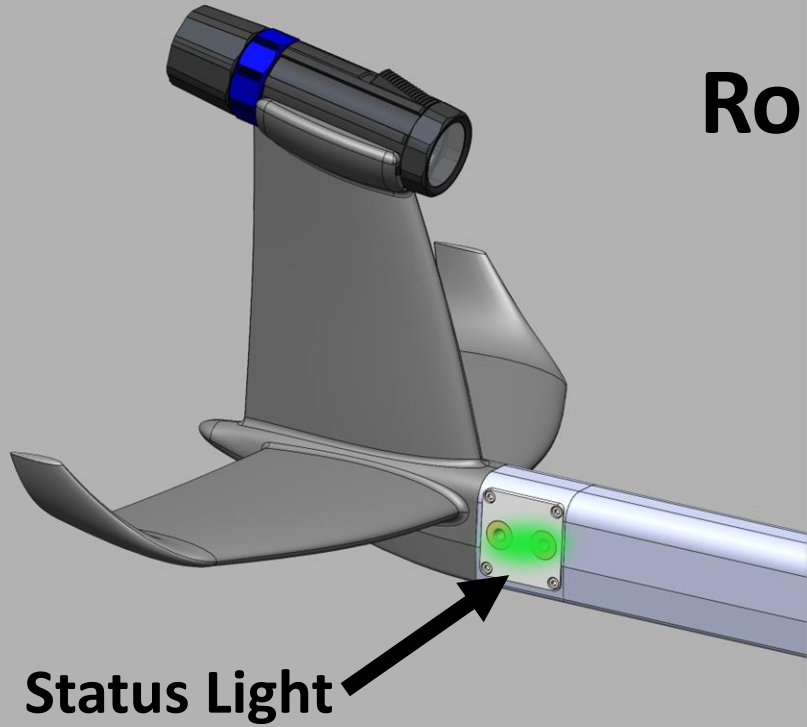

ON	OFF
Pull switch left until status light goes on (2-3 seconds)	Pull switch left until status light goes off (5-7 seconds)

Power ON the robot. A startup sequence initializes. The rudder moves when calibrating its position and the status light goes solid GREEN. If the robot is left still, the rudder will position itself in a dive position. The rudder will continue to move if the robot is not stationary.

Camera – Quick Start Guide

Getting started

Here we present some of the things you need to know, to safely get started with your brand new Paralenz camera.

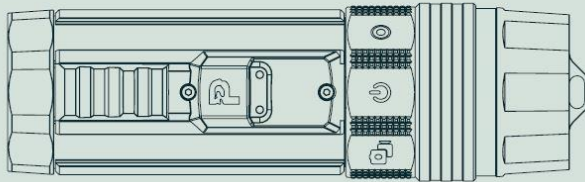

Pull back and hold

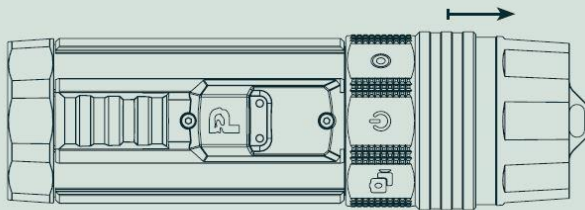

The end cap

The first thing to know about the Vaquita camera is; how to take off the protective end cap for charging or handling the SD-card.

As pictured on the illustrations above, you need to pull back the “collar” on the end cap, to get it off. While holding this back, you will be able to pull off the end cap.

The same mechanism is used when you put the end-cap back on. Pull back the “collar”, push it back on.

SD-Card

Remove the end cap and insert a micro SD-card. **It must be a Sandisk card with class U3 or V30.**

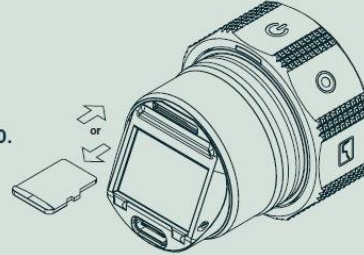

A capacity of **32 GB** or more is recommended. A full memory card is as useful as no memory card! Make sure to empty the SD-card after each export.

Turn on camera

Select the power icon  on the selector ring and hold the activation switch for 4 sec. To turn off again hold for 4 sec. while on Power mode.

Hold 4 sec.

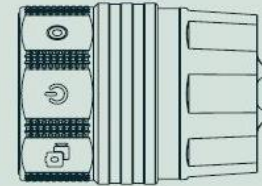
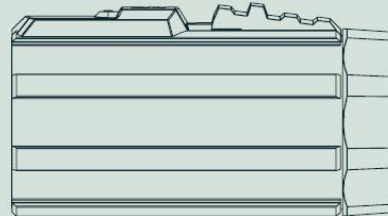

Select mode

Turn the selector ring so the icon of your desired mode is facing upwards. You can choose between the following; Power, Snap, Video, Custom I, Custom II, Settings, Dive Logs, and Location.



Video

To record a video select the video mode on the selector ring, and the camera will confirm with vibration. To start recording hold the activation switch for 1 sec. To stop recording hold for 1 sec.

Battery & charging

Use an USB-C to USB-A charger that can deliver 2.1A for fast charging. Make sure the battery is charged before you enter the water. Maintain the camera battery by charging it every second month, if not in use.

Power ON the camera. Activate the video mode and start recording. Link: [Operating Camera](#)
SD-Card: Extreme, Extreme PLUS or Extreme PRO microSD cards are compatible with the camera.
A capacity of 32 GB or more is recommended (max. 128 GB).



Deployment by the winch in the foreship

While observing over the side, deploy the robot with the winch spooling out at full speed until the robot dives. When the robot dived, reduce the speed to minimum speed ~ 1 meter per minute to ensure overlapping coverage. Verify that the functionality by watching the rope go up and down and sensing variable tension in the rope.



Keep constant watch during the operation.

When maximum length of rope is spooled OUT, flip direction to IN. Continue at the lowest speed, bringing the robot forward.

 If rope tension increases spooling in, the robot is stuck and winch stops, release 2-5m rope and spool in.

When the robot is back at the bow, prior to leaving the water, spool in at full speed.

Stop the winch when the robot is above water and in safe distance from the chock and take it onboard by hand.

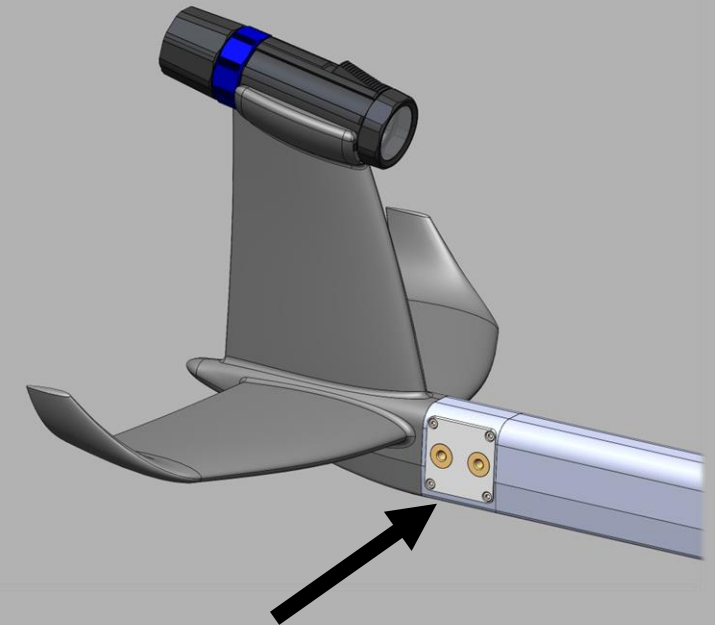
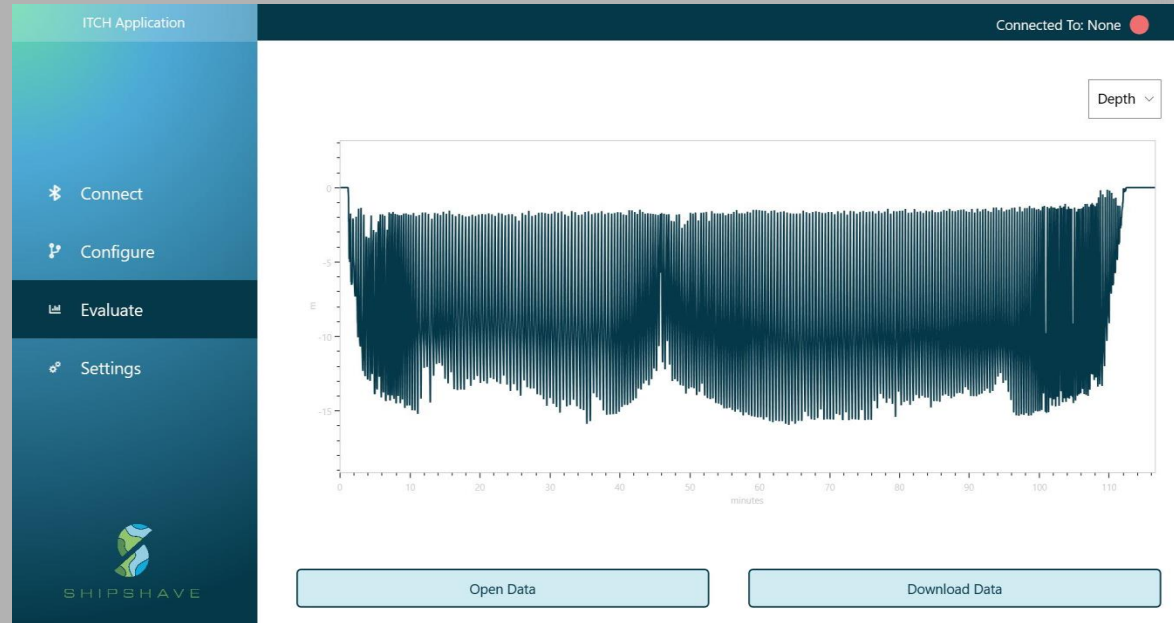
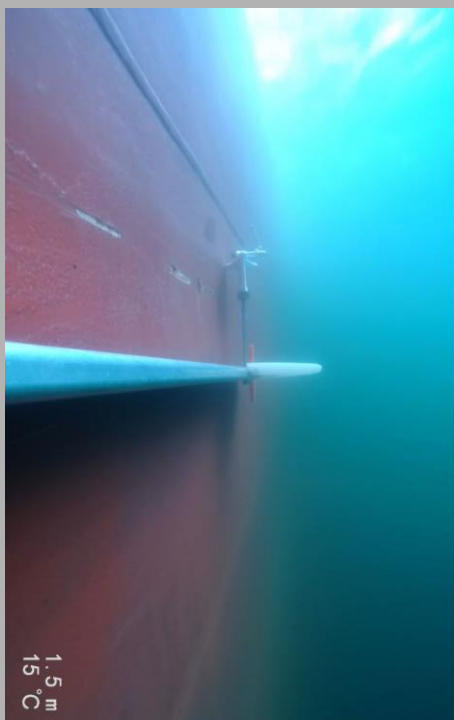

Charging Port



1. Download the recorded video from the memory card in the camera and dataset from the robot.
2. Set up the robot for operation on the opposite side.

After operation on both sides of the vessel, rinse the robot and winch in fresh water and dry. Spray with penetrating oil (WD 40/CRC 565 etc.)

Disassemble and charge the robot and camera.

Fill in the feedback form available in the memory stick and email to support@shipshave.no with the dataset file.

05 - ITCH Application



Installation

- ITCH Application only supports Windows 10 and Windows 11.
- Download installation file from:
 - Included Memory Stick or
 - support.shipshave.no/download
- Open installation file and press install

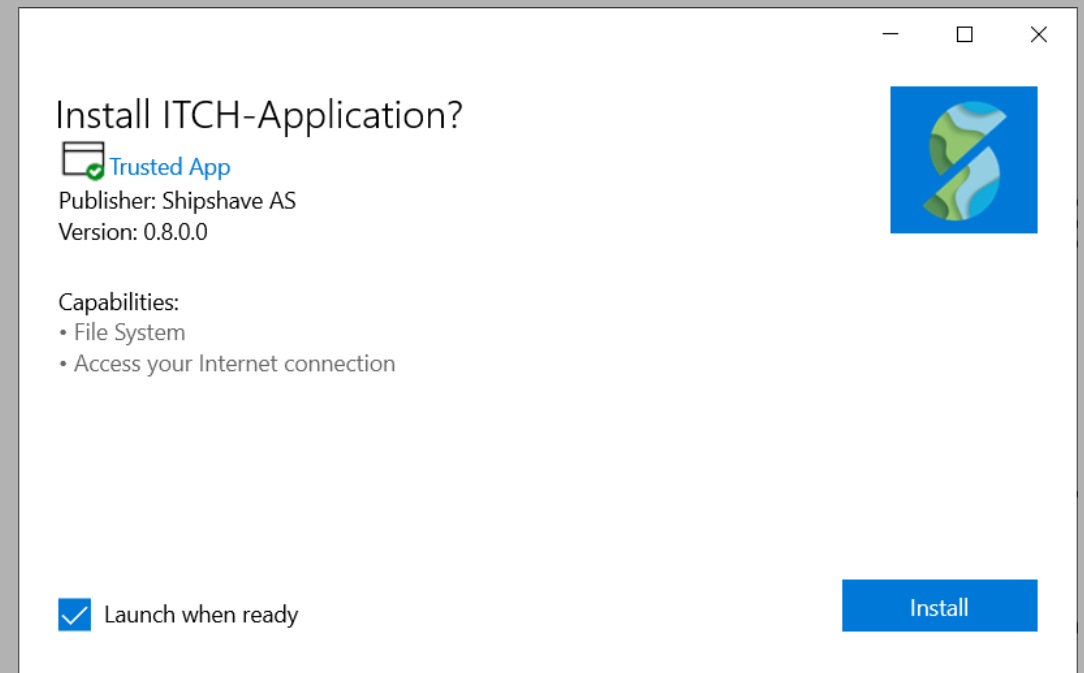

Connect to the Robot

- Turn on Bluetooth on your computer or use the Bluetooth USB adapter
- Turn on Robot and check that status light goes green
- Place Robot close to computer with status light facing computer
- Open application and click “Search For Devices”
- Press “Connect” to the device corresponding to the serial number of the device
- If you have connection problems, press search for devices again and try to re-connect. If this fails, restart Application and Robot.

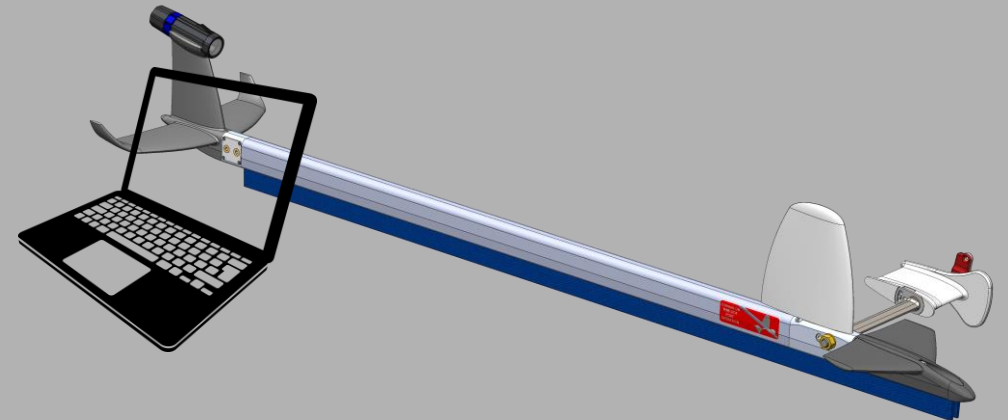
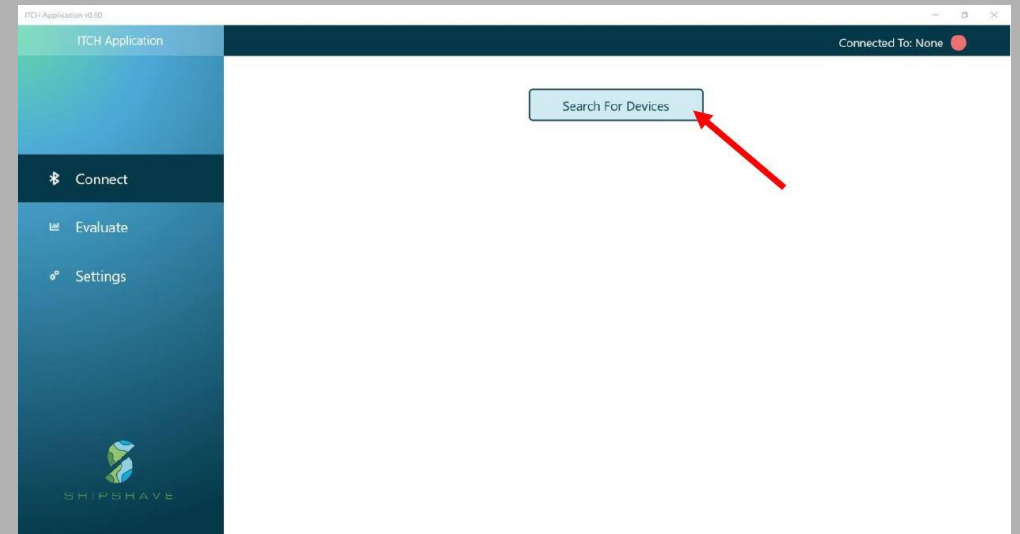

Robot Information

When connected, the connect page will show the following status information about the Robot:

- Robot Hardware Version
- Robot Firmware Version
- Memory Status
- Battery Status

Click “Reload” to update the status information.

Note: **Clear the memory before operating ITCH.**

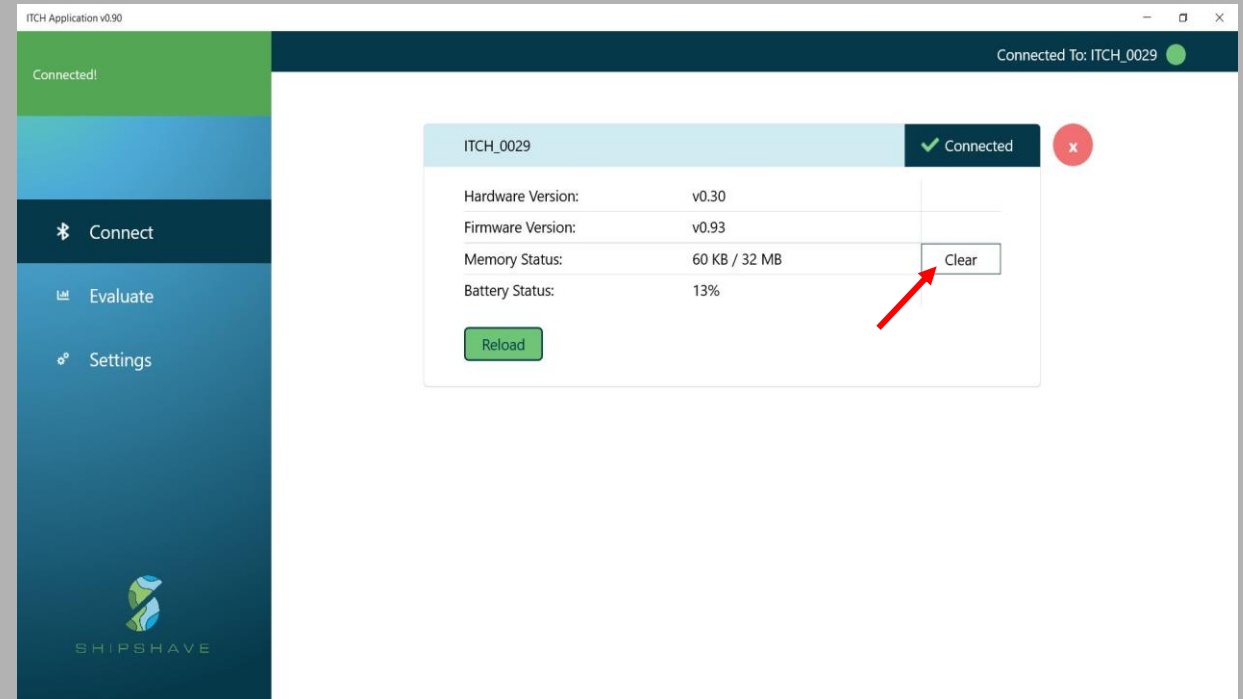

Download Results

To assess the coverage of the robot operation, you can download the sensor data from the robot.

- Press “Download Data” and check that the status light on the robot starts blinking blue
- Wait for the download to complete
- Save the data to your computer (by default, the file is saved to Downloads folder).
- Open previously saved sensor data by pressing “Open Data”

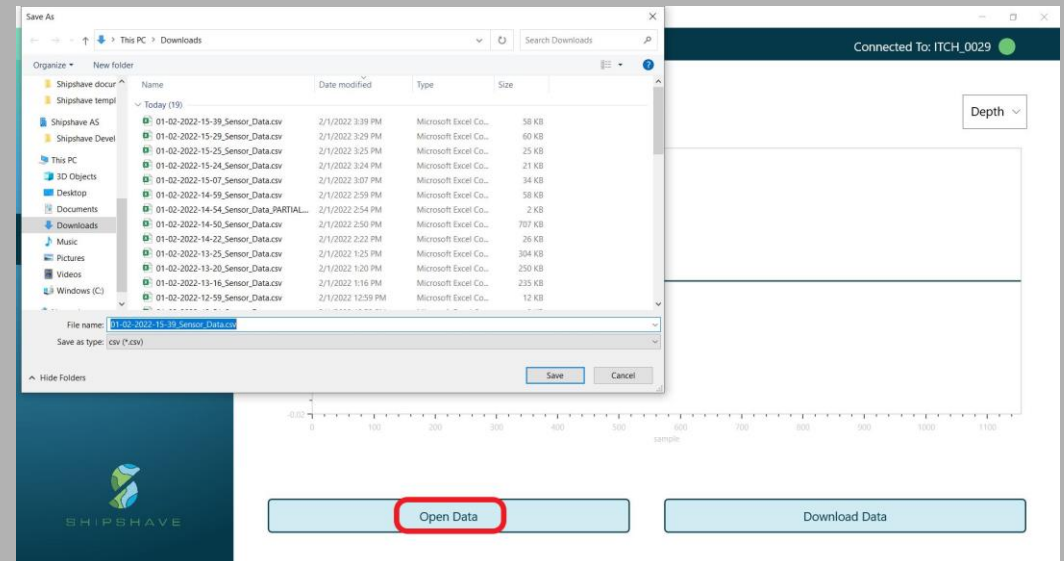
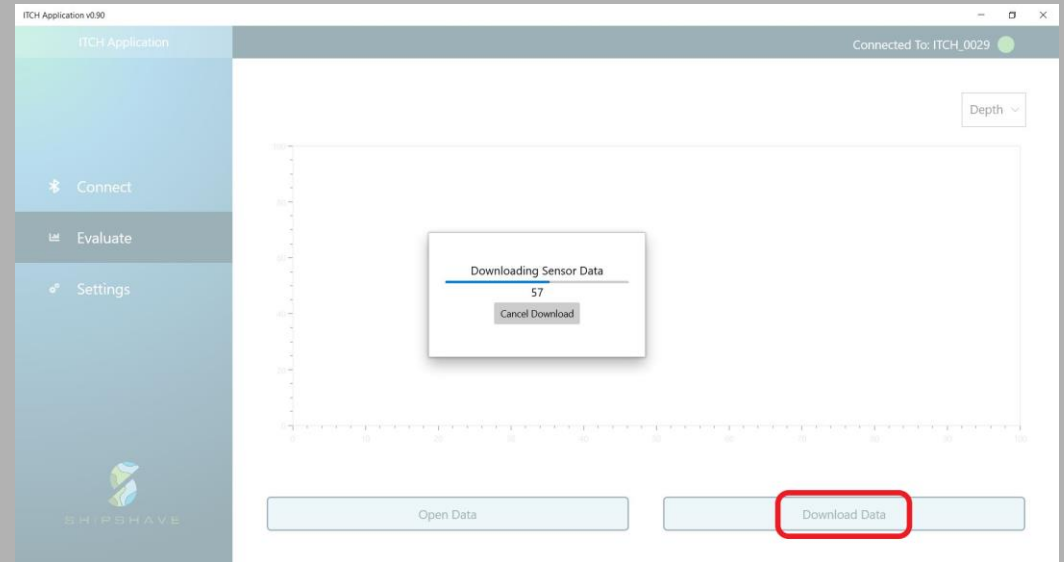

Evaluate Results

The image shows an example of the ITCH results for one run on the hull surface.

- When the Menu is set to **Depth**, the graph shows the coverage of ITCH on the hull.
- **Maximum depth** traversed by the ITCH can be read from the scale as marked in the image.
- When an ITCH operation is completed, the left half of the graph shows the ITCH movement from **fore** → **aft** direction of the vessel. Similarly, the right half shows the ITCH movement from **aft** → **fore** direction.
- The curvature of the hull is more at the bow and aft compared to the parallel middle body of the hull. So, the depth coverage will be more in the parallel middle body part of the hull than at the bow and aft.

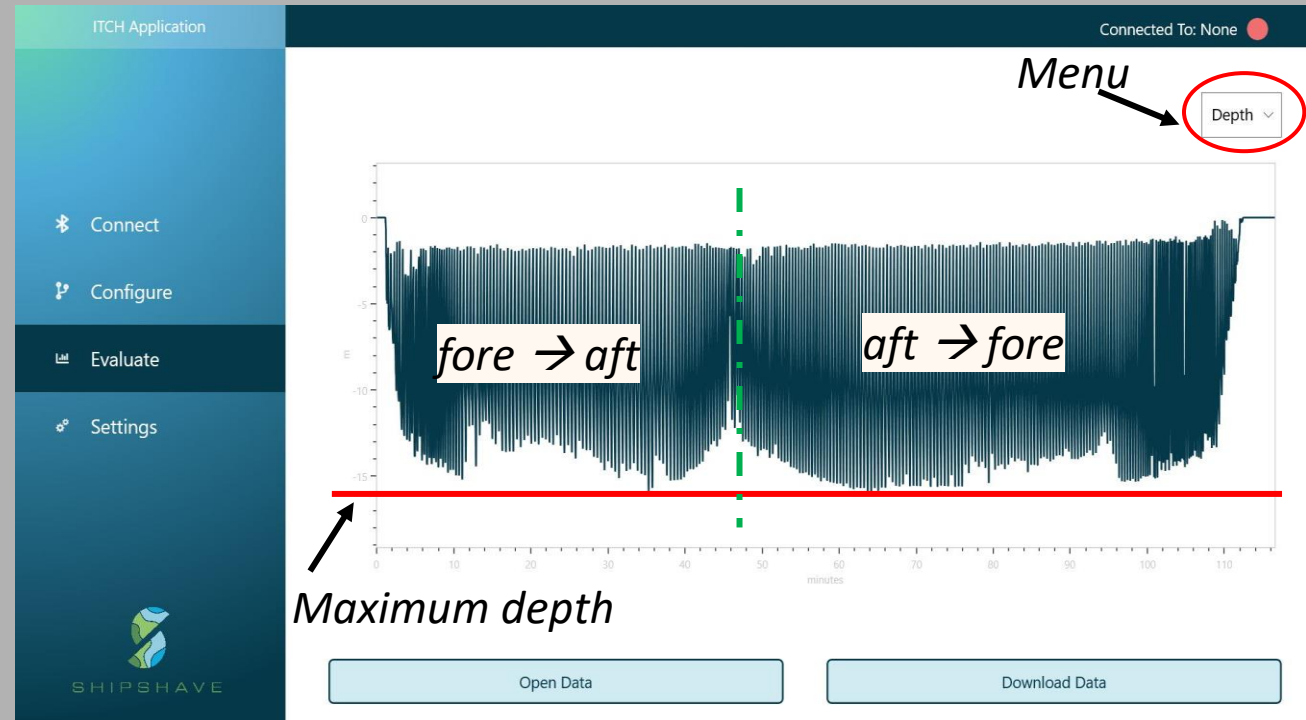

The graph can be navigated by the following gestures:

Action	Gesture
Pan	Right mouse button
Zoom	Mouse wheel
Zoom by rectangle	Ctrl + Right mouse button; Hold and drag the rectangle to the desired area
Reset	Ctrl + Right mouse button double click; Middle mouse button double click
Show tracker	Left mouse button
Reset axes	'A', Home

Depth and Overlap

The maximum depth up to which the ITCH had operated can be found using the “Evaluate” feature in the ITCH Application.

Following measures are recommended to improve the depth coverage of ITCH:

- Deploy ITCH through the center line Panama chock.
- If the operation was carried out in ballast condition, deploy ITCH in fully loaded condition.



An illustration of the ITCH operation with overlap

The efficiency of the ITCH operation is maximum when the robot movement on the hull overlaps. This can be checked from the camera recorded videos. The overlap of ITCH can be controlled by varying the winch speed.

- If the video shows poor overlap of ITCH operation, consider decreasing the winch speed. The recommended winch speed is 1m/min which provides the maximum overlap.

06 – Robot Charging & Status Lights



Robot Charging

Charger LED	Status
Red	Charging
Green	Battery Full or Disconnected



Charger LED

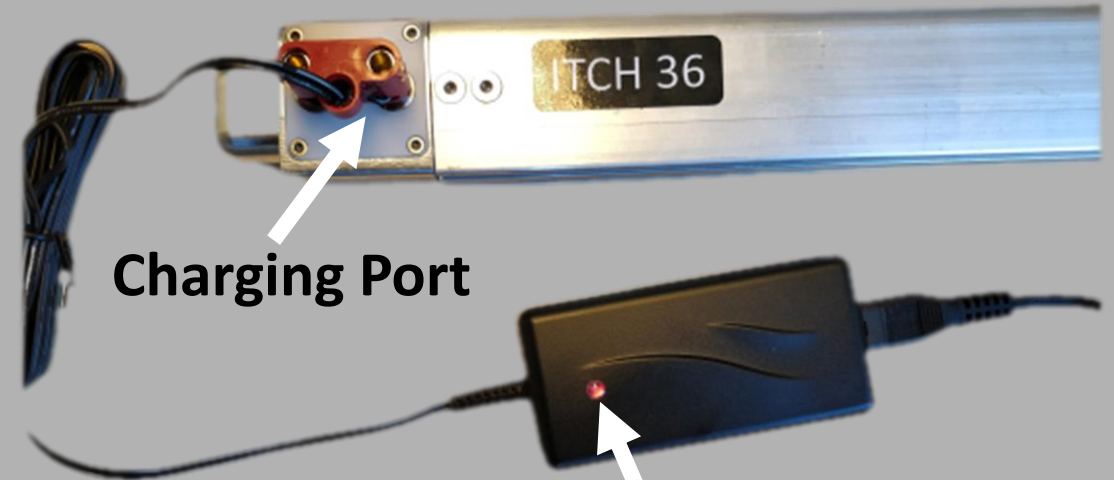

Charging Port

Charging **ON**

*Leave the robot OFF during charging

Robot Status Light

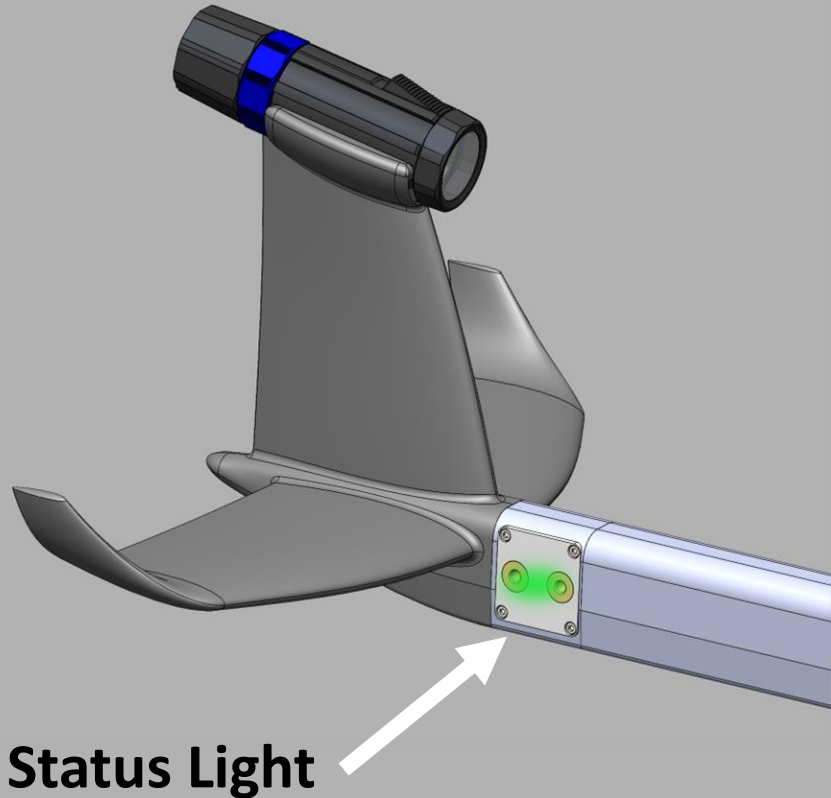

Status Light Colour	Operational Status
Green	Everything ok, ready for cleaning
Solid Red	Error, please restart Robot
Blinking Red	Battery Low (Turns off automatically after 1 minute)
Solid Blue	Firmware Update Mode
Blinking Blue	Download Data Mode

07 – Camera Operation



Operating Camera

- **Turn on:** Position selector to Power and hold activation switch until it vibrates
- **Start Recording:** Position selector ring to Video and pull activation switch
- **Stop Recording:** Position selector ring to Video and pull activation switch
- **Turn off:** Position selector ring to Power and hold activation ring until the display turns off

Activation Switch:

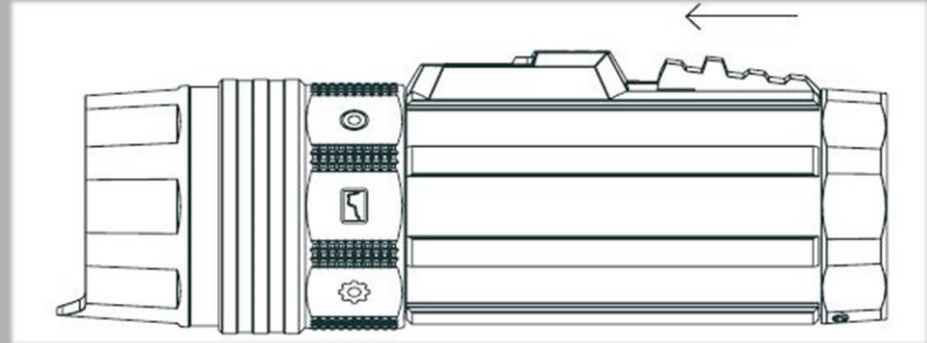

Mode Selector:

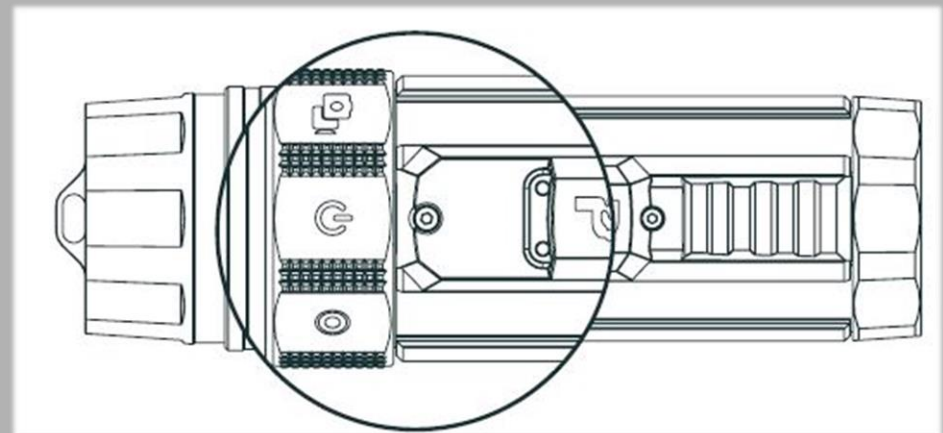

Retrieve Videos

- Pull Off the End Cap
- Pull out Micro SD card
- Connect Micro SD card to computer
- Copy files from SD card to computer
- Delete old files from SD card
- Place SD card in camera
- Pull back the lock ring on the end cap and push the end cap back

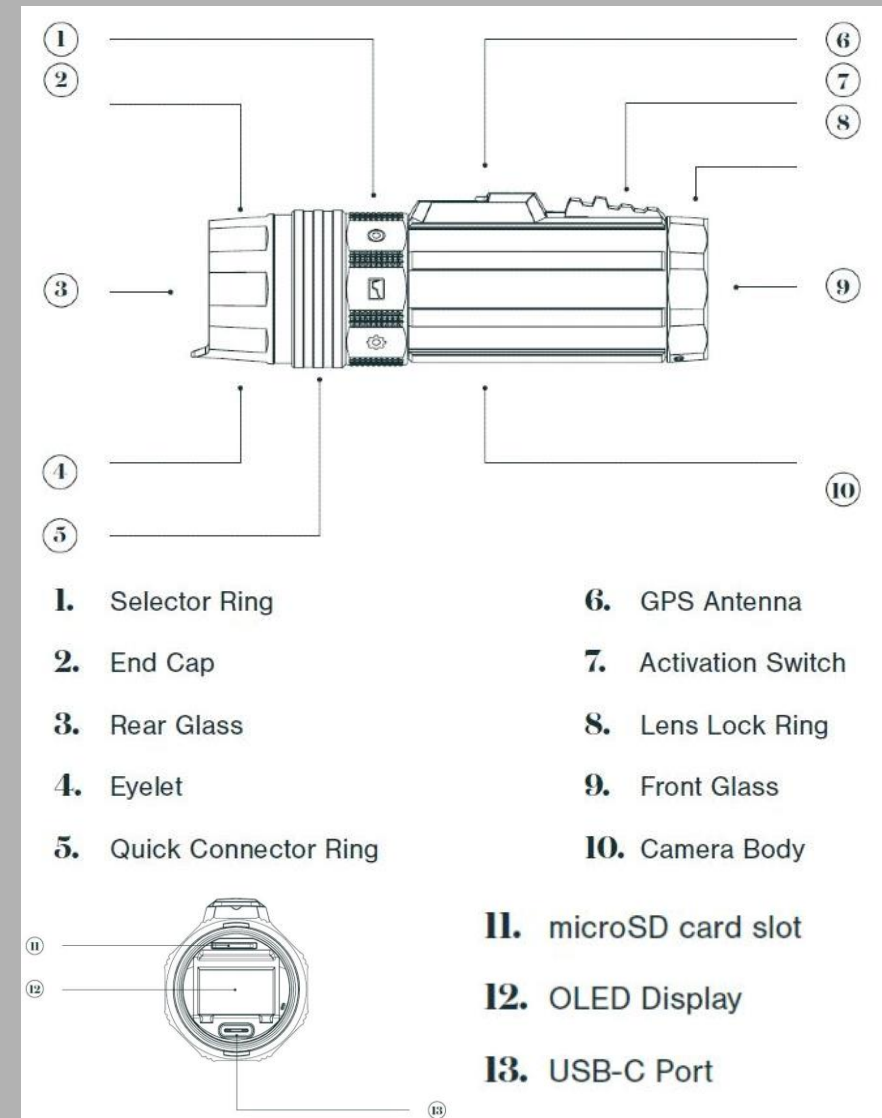

Charging Camera & recommended settings

- Check battery status on the display
- Fully charge the camera before operating
- Open the end cap and plug the USB C cable into camera and connect it to a computer or a USB charger

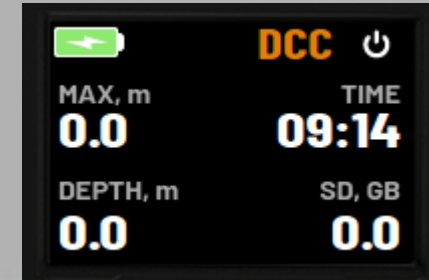

Name	Recommended setting
Resolution	720P
Frames Per Second (FPS)	30
White balance / Dynamic Colour Correction (DCC)	DCC Green

Camera Maintenance

- Rinse camera in fresh water after use
- Dry with a cloth before opening
- Replace O-Rings if damaged
- Ensure O-Rings have sufficient silicon grease

More information about the camera can be found in the Paralenz Camera User Manual found in the included memory stick, and in Appendix herein.

08 - Safety Precautions



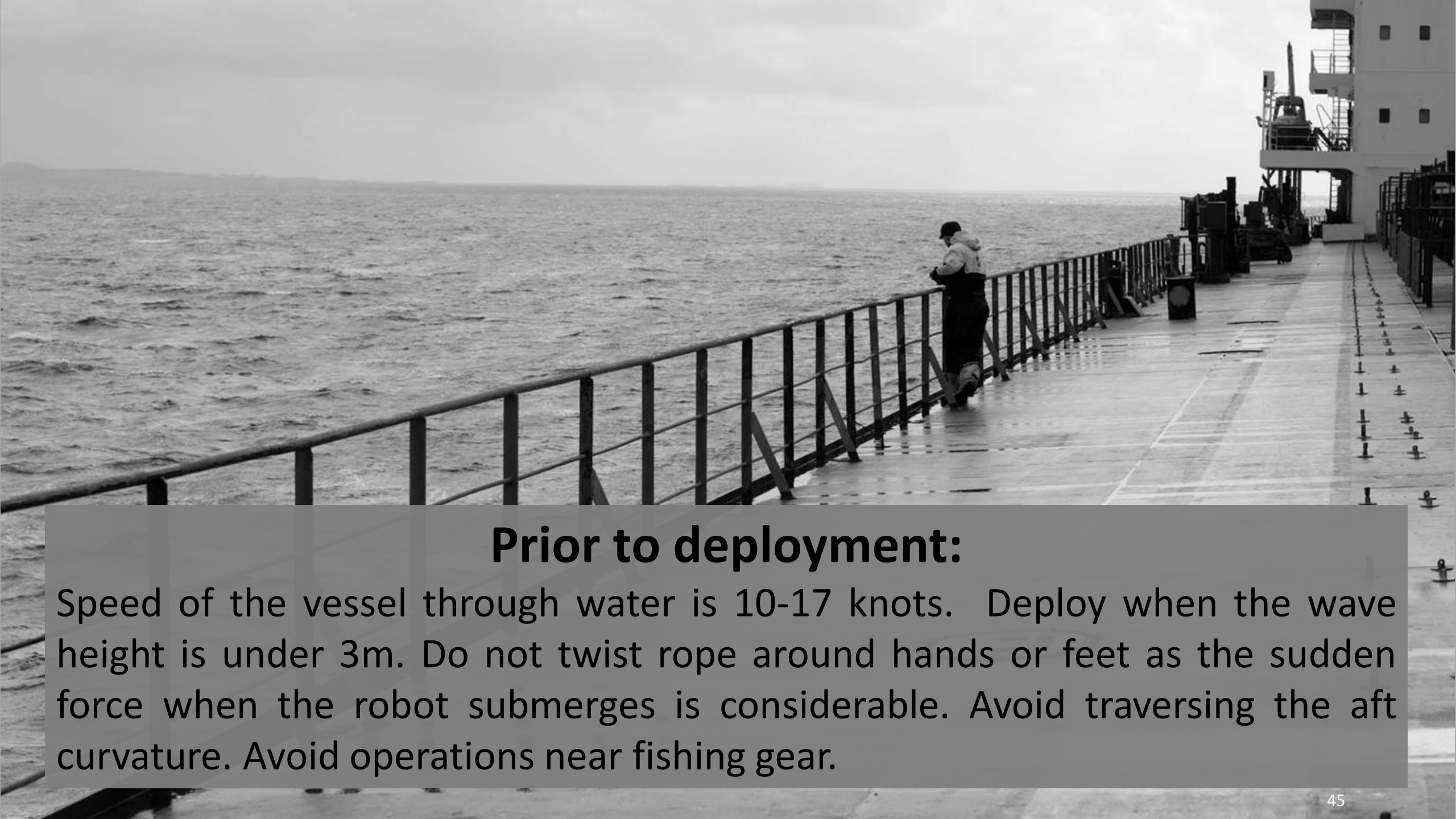

Prior to deployment:

Speed of the vessel through water is 10-17 knots. Deploy when the wave height is under 3m. Do not twist rope around hands or feet as the sudden force when the robot submerges is considerable. Avoid traversing the aft curvature. Avoid operations near fishing gear.



During operation:

Obstacles on the hull may be encountered during cleaning. Maintain watch and apply good seamanship to ensure the operation is proceeding as planned. Should the robot not operate according to plans, stop the operation and retrieve the robot. Inspect the robot and rope for damages. Review the operation parameters and the acquired data.



Rope safety:

During operation, the rope tension will vary from high to very low. Ensure the thin rope does not become trapped in small gaps which could damage the rope. Watch the spooling of the rope and adjust if required. Make sure the rope does not reach the propeller.



Winch:

The winch contains a powerful electric motor with a rotating drum. Stay away from moving parts and work from a safe distance. Avoid unessential personnel near the winch during cleaning. Avoid foreign objects close to the rotating parts of the winch. Maintain 4 turns of the rope on the drum of the winch.

If you have any questions,
contact support@shipshave.no

(Include the dataset file, a few images from the recorded video and your feedback in the email)



Appendix A – Replacing the Camera





The camera is securely fastened to the tail using the grooves in the camera. During normal operation a user should not have to remove the camera from the tail. If there is a camera or tail malfunction, the camera can be removed and replaced by the following instructions. **This operation should not be done outdoors.**

Removing the Camera



Step 1 of 4:

Unscrew and remove the end cap to expose the charging port.



Step 2 of 4:

Grip around the green ring and pull it back towards the rear of the camera. It will click and slide off the camera.

Removing the Camera



Step 3 of 4:

Carefully remove the 2 pieces of the selector ring from the camera body and set in a safe place.



Step 4 of 4:

Slide the camera forward and out of the tail. The camera body should now be free from the tail.

Installing the Camera



Slide On →



Step 1 of 4:

Prepare new camera for mounting by removing end cap, green ring, and plastic selector pieces as described in the camera removal procedure above.

Step 2 of 4:

Align grooves in camera body with the grooves in the tail. Ensure that the camera orientation is vertical with the camera switch pointing up.

Carefully slide the camera backwards until it stops against the tail.

Installing the Camera



Magnet on top



Hole on bottom

Hole on top



Magnet on top



Step 3 of 4:

Install plastic selector ring pieces onto camera body. Ensure the magnet is on top of the camera as shown in the picture.

Installing the Camera



Step 4 of 4:

Slide on the green ring and align the 2 notches in the green ring with the 2 tabs on the plastic selector ring, such that the power button is on top and snap button (⦿) is on the left side of the camera. The ring should push on and snap into position. If the ring does not snap into position, check the 2 notches in the green ring are in alignment with the 2 tabs on the selector ring. Finally, screw on the end cap.

Appendix B – Advanced Settings



Procedure to access Advanced mode on ITCH Application

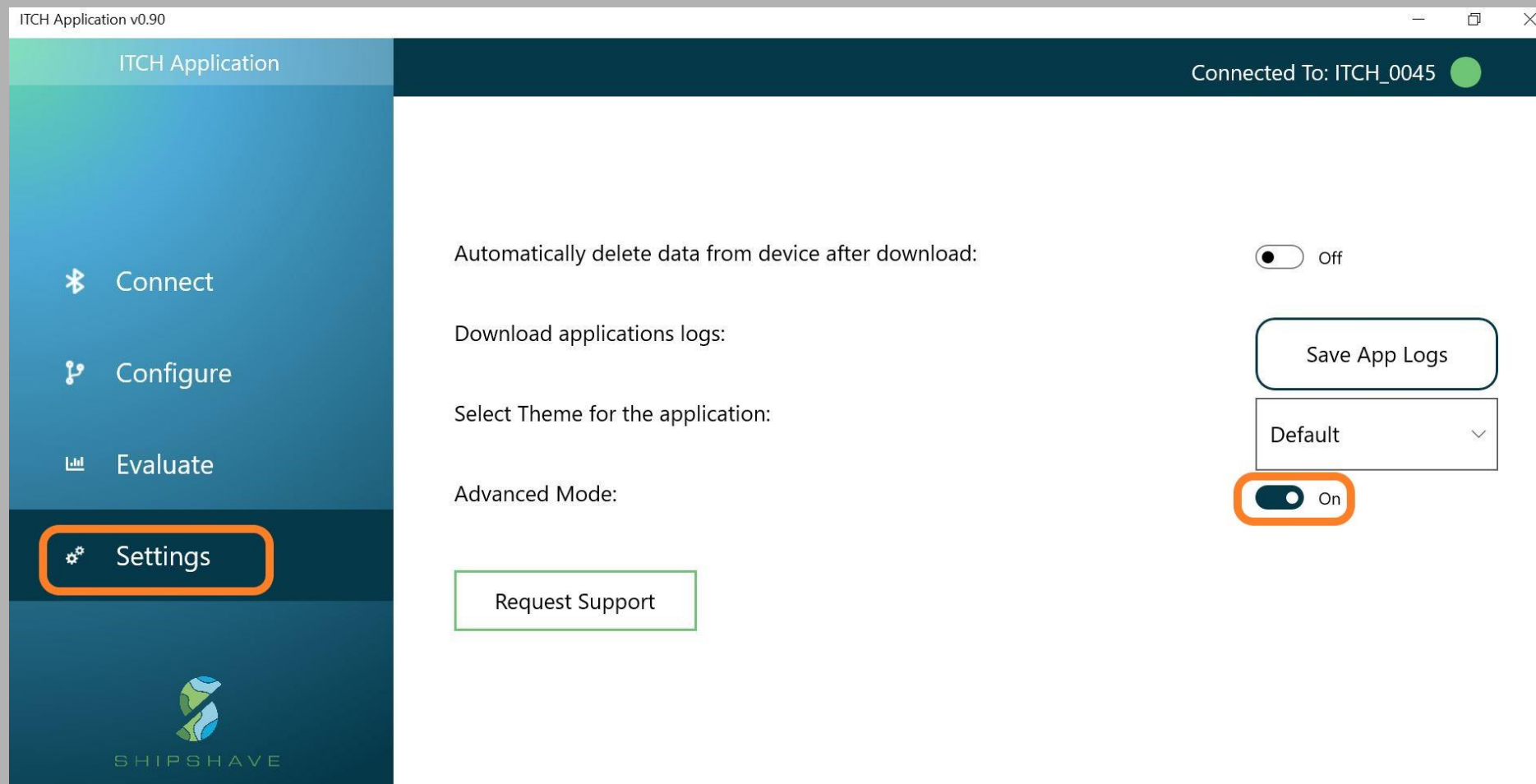

Step 1 of 5: Open the ITCH App and go-to the Settings tab. Click and put the slider to “On” to activate Advanced mode.

Procedure to access Advanced mode on ITCH Application

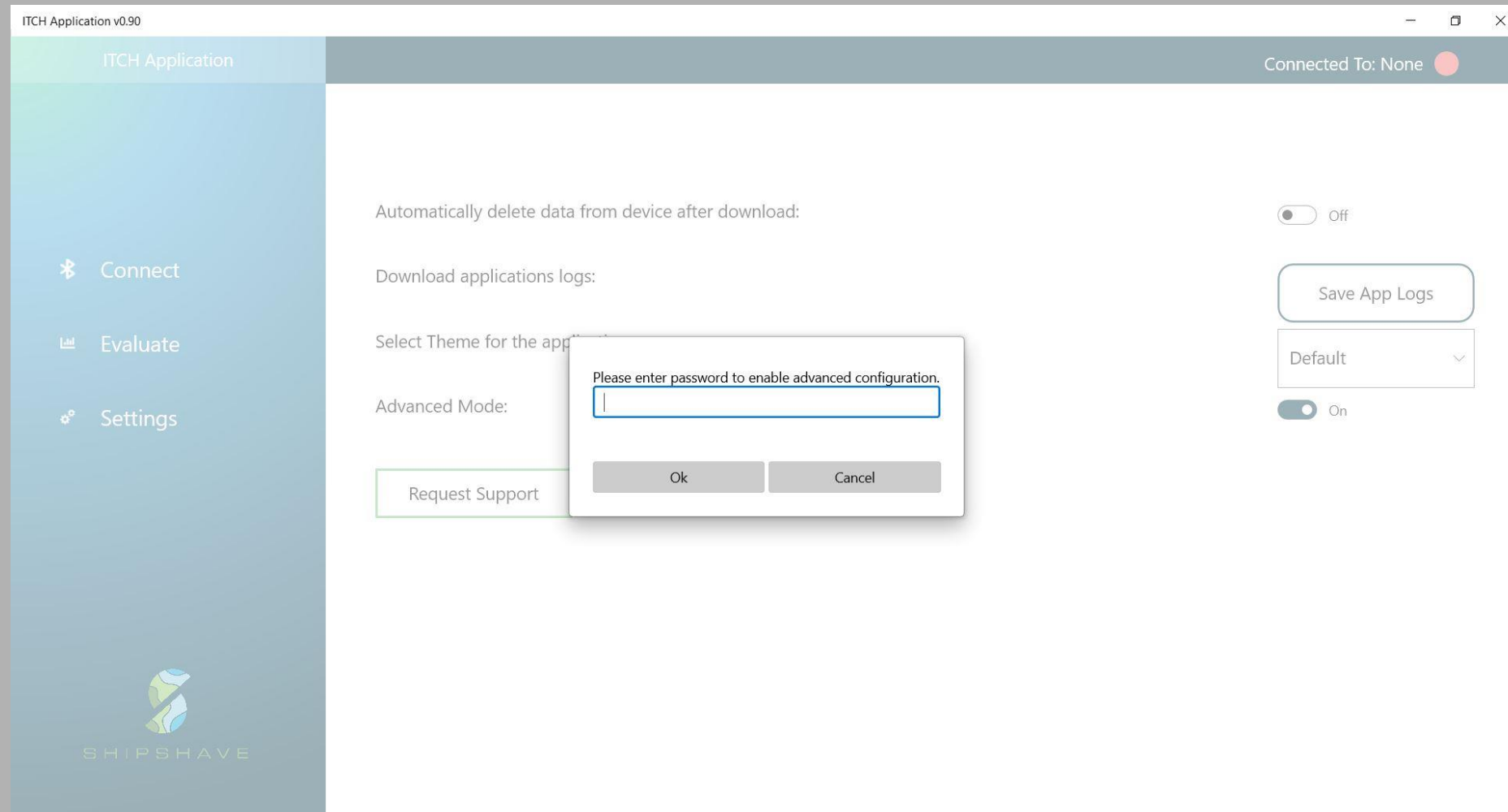

Step 2 of 5: Enter the password to enable advanced mode. The default password is set as **“admin”**.

Procedure to access Advanced mode on ITCH Application

ITCH Application v0.90

ITCH Application

Connected To: None

Connect

Configure

Evaluate

Settings

Current Config		New Config
Upper Depth [m]	→	Upper Depth [m]
Lower Depth [m]	→	Lower Depth [m]
Rudder Speed	→	Rudder Speed
Max Robot Speed [m/s]	→	Max Robot Speed [m/s]
Max Roll [deg]	→	Max Roll [deg]
Rudder Window [deg]	→	Rudder Window [deg]
Setpoint Delta [m/cycle]	→	Setpoint Delta [m/cycle]
Timeout [s]	→	Timeout [s]
Max Down Rudder Angle	→	Max Down Rudder Angle [de]
Max Up Rudder Angle	→	Max Up Rudder Angle [deg]

Reset config

Default config

Upload config

Load config

Save config

Read config

SHIPSHAVE

Step 3 of 5: Click the Configure tab. Enter the new configuration values in the rows under “New Config”. Then click the Upload button to activate the new configuration.

Procedure to access Advanced mode on ITCH Application

ITCH Application v0.90

Connected To: ITCH_0045

ITCH Application

Connect

Configure

Evaluate

Settings

	Current Config	New Config
Upper Depth [m]	1.5	1.5
Lower Depth [m]	20	20
Rudder Speed	3000	3000
Max Robot Speed [m/s]	1	1
Max Roll [deg]	35	35
Rudder Window [deg]	12	12
Setpoint Delta [m/cycle]	0.2	0.2
Timeout [s]	10	10
Max Down Rudder Angle	15	15
Max Up Rudder Angle	12	12

Reset config

Default config

Upload config

Load config

Save config

Read config

SHIPSHAVE

Step 4 of 5: Click the Configure tab. Enter the new configuration values in the rows under “New Config”. Then click the Upload button to activate the new configuration.

Procedure to access Advanced mode on ITCH Application

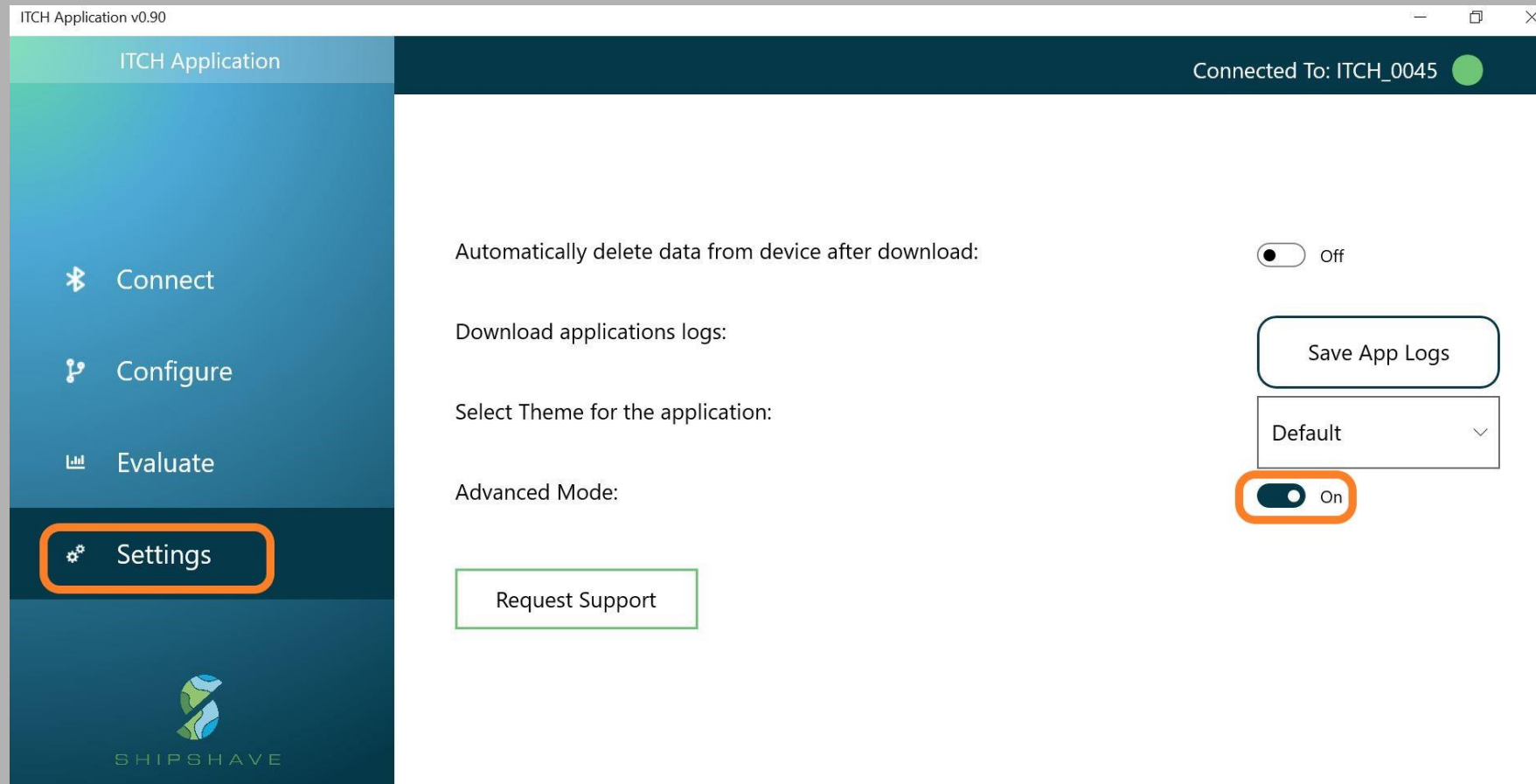

Step 5 of 5: Click the Settings tab again. Click and put the slider to “Off” to exit from the Advanced mode.

Appendix C

Custom Depth Settings



Custom depth settings

As default, the ITCH is programmed to oscillate between 1.5m depth and 20m depth. It will change direction at the curvature towards the flat bottom. The max roll ensures that the ITCH does not go deeper than the curvature.

- **The Upper Depth** can be set shallower than 1m, but beware ITCH may pop out of the water while going up. It may be set deeper to avoid cleaning hull surface area without fouling.
- **The Lower Depth** may be set to a depth to avoid obstructions on the hull, but ITCH is protected from going past the curvature with the "Max Roll" feature.

	Current Config	New Config
Upper Depth [m]	1.5	4
Lower Depth [m]	5	10
Rudder Speed	3000	3000
Max Robot Speed [m/s]	1	1
Max Roll [deg]	35	35
Rudder Window [deg]	12	12
Setpoint Delta [m/cycle]	0.2	0.2
Timeout [s]	10	10
Max Down Rudder Angle [deg]	15	15
Max Up Rudder Angle [deg]	12	12

Buttons: Reset config, Default config, Upload config, Load config, Save config, Read config

Verify that "Current Config" updates to the same as "New Config" after pressing Upload Config.

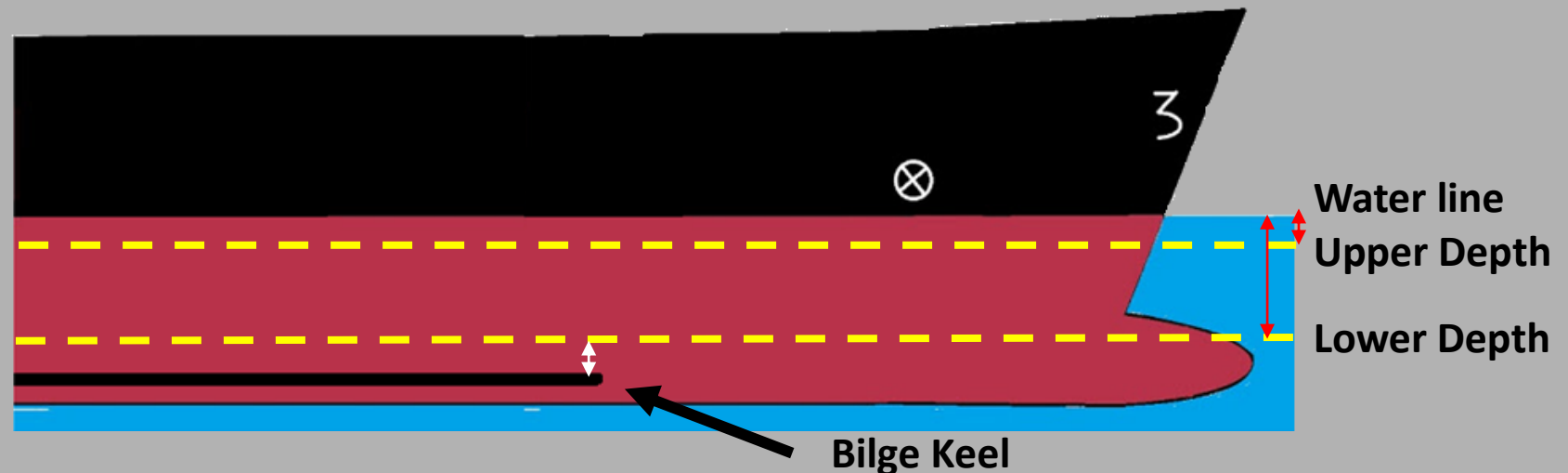

Appendix D

High-Speed Ships



Operating ITCH on High-Speed Vessels

Proposed ITCH Robot settings for ITCH on vessels capable of sailing at speeds above 15 knots:

- **Configuration:** Set “*Max Roll*” to 50 degrees, “*Upper Depth*” to 2m and “*Lower Depth*” to 3m above the least of fore and aft draft of the ship. Refer to Appendix B for more information on how to change advanced settings.
- **Preparation:** Check if the bow thruster tunnel starts at least 6m draft. If the tunnel is at a draft less than 6m, contact Shipshave for assistance (support@shipshave.no).
- **Deployment & Operation:** Deploy from center line Panama chock. Make sure the rope has a clear path and doesn't risk getting stuck in the anchor during deployment and retrieval.
- We recommend performing the first cleaning at 12-14 knots and calm seas. Inspect video after the operation focusing on distance to thrusters and bilge keels. Use the information for next operation to optimize "lower depth".

ITCH Application v0.93 Connected To: ITCH_0113

ITCH Application

Connect

Configure

Evaluate

Settings

	Current Config	New Config
Upper Depth [m]	1.5	1.5
Lower Depth [m]	10	10
Rudder Speed	3000	3000
Max Robot Speed [m/s]	1	1
Max Roll [deg]	50	50
Rudder Window [deg]	12	12
Setpoint Delta [m/cycle]	0.2	0.2
Timeout [s]	10	10
Max Down Rudder Angle [deg]	15	15
Max Up Rudder Angle [deg]	12	12

Reset config

Default config

Upload config

Lower Depth: The lower depth input value depends on the draft of the ship during ITCH operation. For e.g., if the draft of the ship is 12m and the bilge keel is located at a draft of 10m (refer mid-ship section plan), then the “Lower Depth” value should be “9” (1m less than bilge keel draft).

Appendix E

Brush selection



Enhancing Hull Performance and Maintenance

- **Minimizing drag and fouling Growth:** Maintaining a smooth hull surface with low roughness and minimal fouling optimizes hull efficiency.
- **Soft Bristle Brushes:** Shipshave's soft bristle brushes are designed to ensure minimal wear on the hull paint coating while effectively removing the fouling.
- **Choosing the right brush**
 - a) New/Silicone Paint with Light Fouling: Use soft black or the softest white bristles.
 - b) Established Fouling/Green Grass: Choose blue brushes for more robust cleaning.
 - c) Barnacles: Get the specialized Barnacle tool from Shipshave.
- **Post-cleaning check**
 - a) Review Cleaning Videos: Evaluate cleaning efficacy.
 - b) Incomplete Cleaning: If needed, rerun the process for thorough cleaning.

Appendix F Maintenance



Maintenance of ITCH

- **After every operation:** Rinse the robot and winch with fresh water to remove salt. Spray with penetrating oil (WD 40/CRC 565 etc.), particularly the switch area.



- **Rope on the winch:** Check the rope condition after every operation for wear. If there is wear at the end of the rope where ITCH is tied, cut away the worn part and retain the rest. If the blue core is exposed, or significant wear is seen, replace the rope.



- **Brushes and outriggers:** Replace worn brushes and outriggers.
- **Storage:** Store and secure the robot and the winch where the ambient temperature is below 45° C.

For replacement of ITCH, accessories or any components, contact "support@shipshave.no"

